

# Quick troubleshooting guide



## Troubleshooting Electrical 12 Vdc TIXIT cover



## SUMMARY

CHECKING THE VOLTAGES OF THE AQUA9 CONTROL BOX .....	p.3
MOST FREQUENTLY ENCOUNTERED PROBLEMS .....	p.4
A/ Check the power source: measure the voltages supply and motor power to the control box .....	p.5
B/ Check the supply voltage arriving at the terminal and on the motor connector (expected measurement: around 17 VDC) .....	p.6
C/ Check the polarity of the motor power supply .....	p.7
D/ Unplug the automatic switch to check that it is not faulty (if present because optional) .....	p.8
E/ Short-circuit the control .....	p.9
F/ Increase the limit switches .....	p.10
G/ Realign the limit switch rings (checking the rotation of the rings at the same time as the tube) .....	p. 11
LED WIRING DIAGRAM .....	p. 12
1/ The LEDs do not light up or no longer light up. ....	p. 13 à 15
2/ One LED is constantly lit and the 2nd operates via the ON/OFF pushbutton. ....	p. 16
POOL SOUND WIRING DIAGRAM .....	p. 17 à 19
BLUETOOTH PAIRING PROCEDURE .....	p. 20

## CHECKING THE VOLTAGE OF THE CONTROL BOX

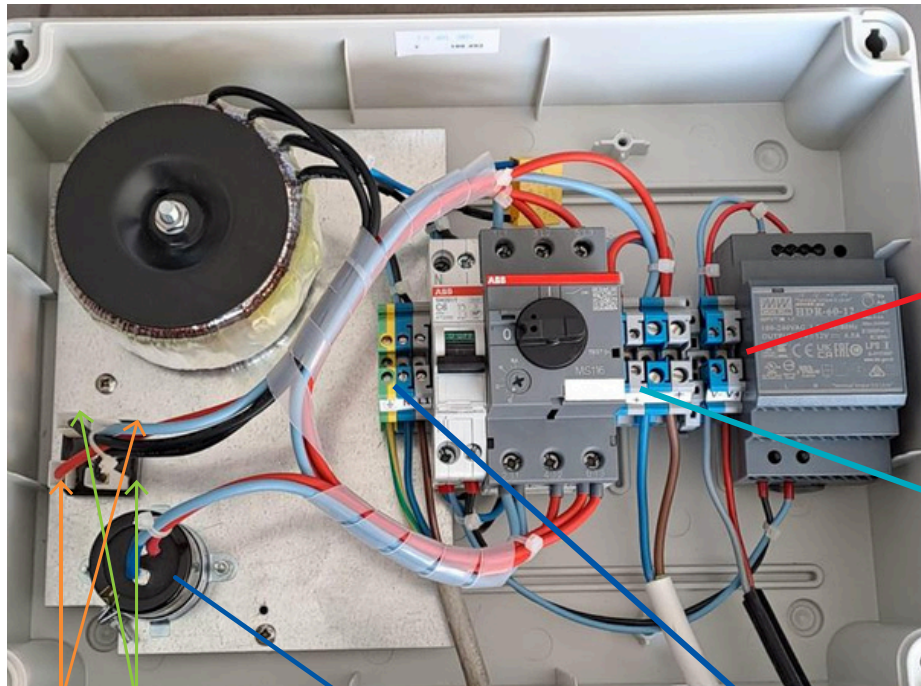

12 to 17 Vdc

12 to 17 Vac

Smoothing capacitor  
22000 $\mu$ F

Mains (230Vac)

TERMINAL BLOCK V+/V-  
LED (+ POOL SOUND  
option)

TERMINAL BLOCK  
+/-12V motor power  
supply (12-17Vdc)

# MOST FREQUENTLY ENCOUNTERED PROBLEMS

Consult and follow the table provided for each troubleshooting.  
 Proceed with each corresponding action sequentially until you identify the issue, enabling you to troubleshoot and fix the problem.

**The operations described in this guide must be performed by a professional with appropriate electrical authorization (in accordance with applicable standards).**

TROUBLESHOOTING	ACTIONS TO BE CARRIED OUT						
	A	B	C	D	E	F	G
The motor does not run/no longer runs.	X	X	X	X	X	X	
The motor runs in reverse.	Reverse the opening and closing wires						
The motor only/more than turns in one direction.				X	X	X	X
The motor is slow or noisy.	X	X					
The limit switches shift.							X
The motor runs continuously when powered on.					X		

## NECESSARY TOOLS

The multimeter must be set up to measure direct current:

Symbol 

Multimeter



Screwdriver



5-10cm cable



## A / Check the power source: measure the power supply and motor power voltages at the electrical box

- 1 | Take the voltage from the power terminal block between L1 and N. It should be approximately 230Vac.



If necessary, check the voltage upstream of the box on the main panel.

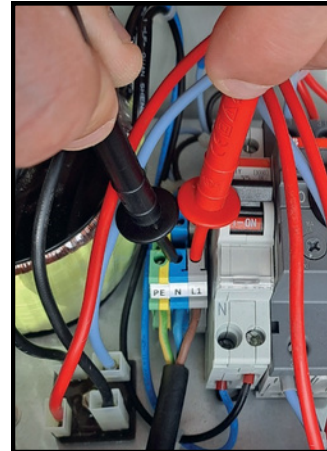

- 2 | Measure the Motor Terminal Block Voltage: it should be approximately 17 VDC.

⚠ However, if the motor has not been used for a while, you may notice higher voltage. This phenomenon is explained by the maximum charge of the capacitor.



If necessary, check the different voltages in the box (see page 3).

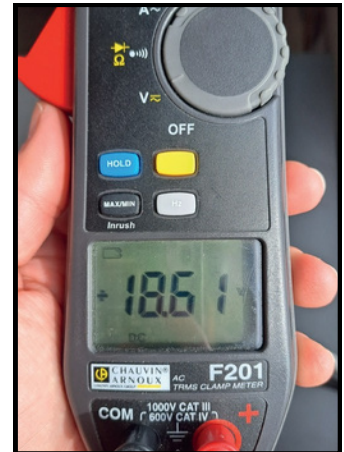
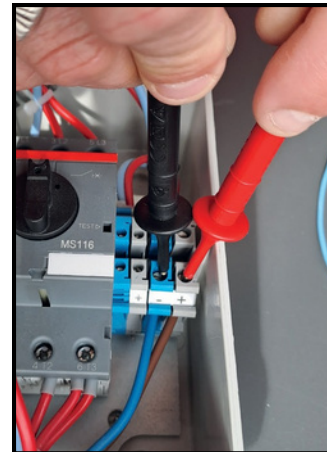

## B / Check the supply voltage arriving at the terminal as well as on the motor connector (expected measurement: approximately 17 VDC)

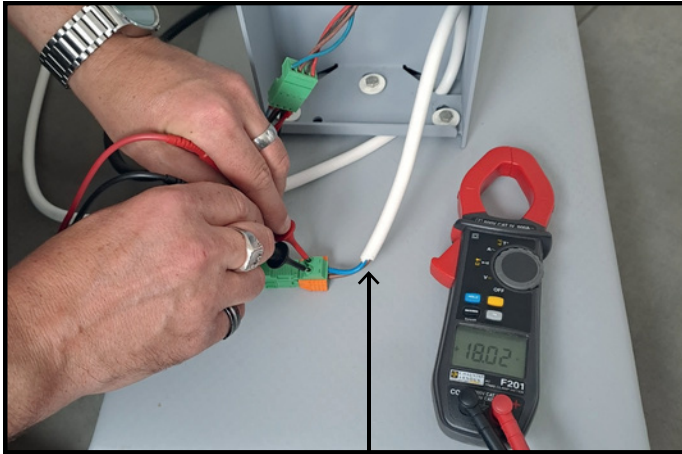

Cable coming from  
the box

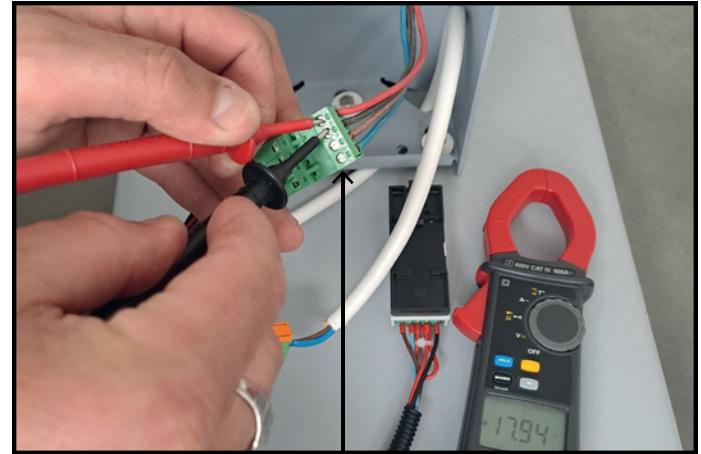

Motor connector



If the tension is not correct, inspect the cable that connects the connector to the control box. You can also test the connection using a spare cable.

## C/ Check the polarity of the motor power supply

The red probe of the multimeter must be positioned on the red wire and the black probe of the multimeter on the black wire.



Positive voltage



Negative voltage

**To ensure the motor operates correctly, the voltage on the connector must be positive.**

 If necessary, interchange the positions of the two wires coming from the control box.



## D/ Disconnect the automatic switch (electronic card) to check that it is not faulty (if present because optional)

Disconnect the input and output connectors from the electronic card then reconnect the direct connectors.

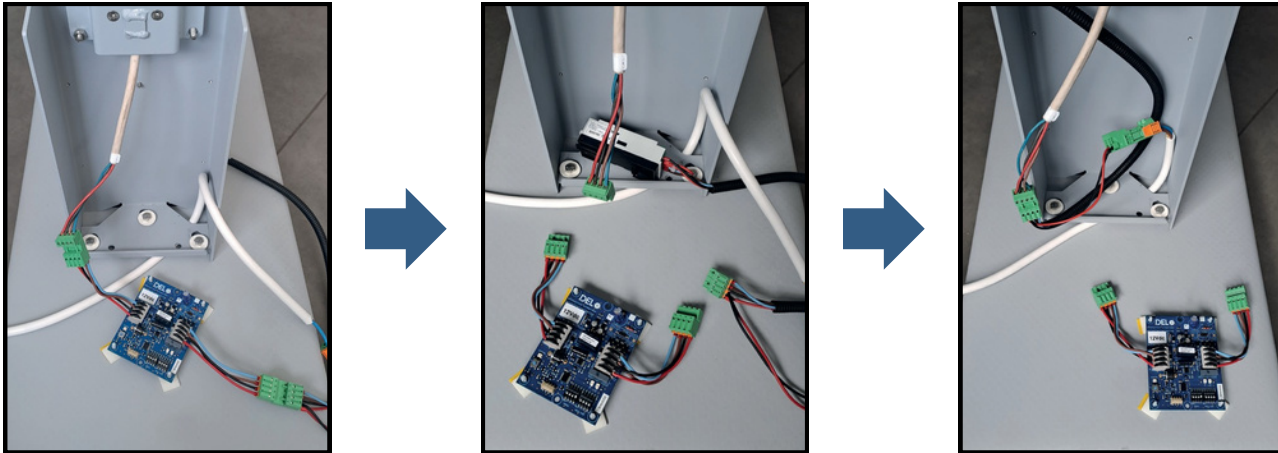

If the installation works again, replace the automatic switch.

## E/ Shunt the control system

At the motor connector, make a bridge between the red and brown wires then between the red and blue wires.

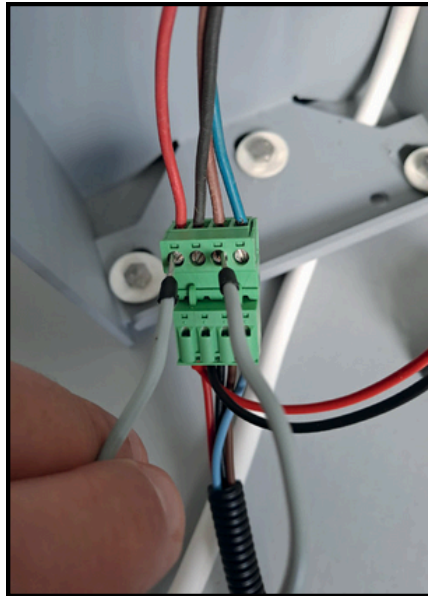
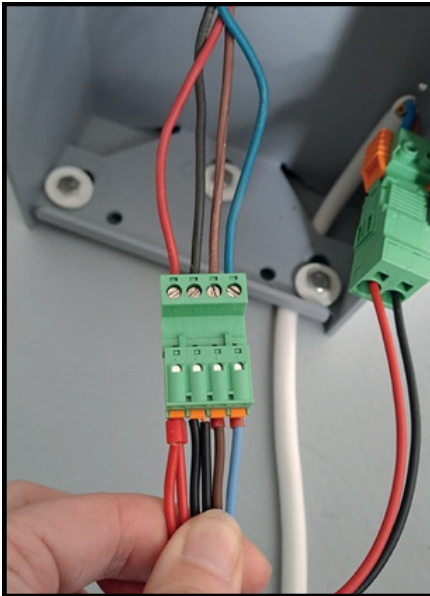

If the installation works when shunted, check and/or replace the control system (key switch or Wi-key).

## F/ Increase the limit switches

- +
  - 
  - ↕
- By turning in the + direction, you increase the range of movement of the cover.
- By turning in the - direction, you reduce the range of movement of the cover.
- The arrows indicate the direction of movement of the cover.

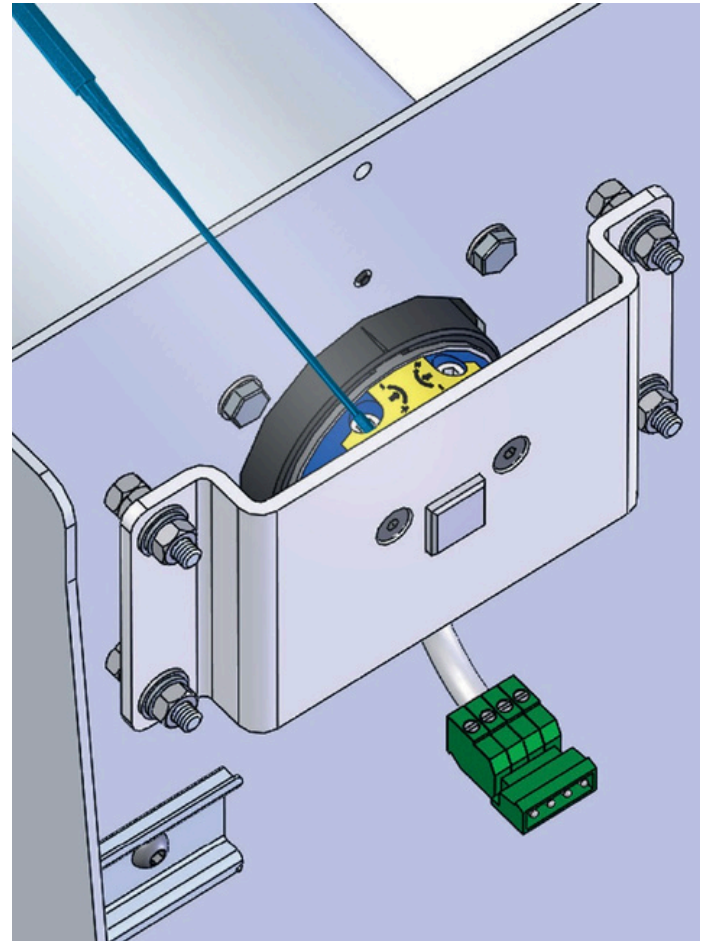

## G/ Realign the limit switch rings while checking the rotation of the rings along with the tube.

The limit switch connecting ring of the tube must drive the grey ring of the motor when the cover is being rolled or unrolled.

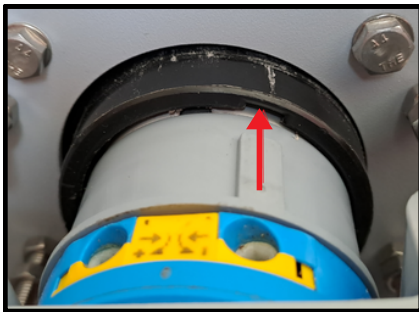

Limit switch connecting ring

Grey motor ring

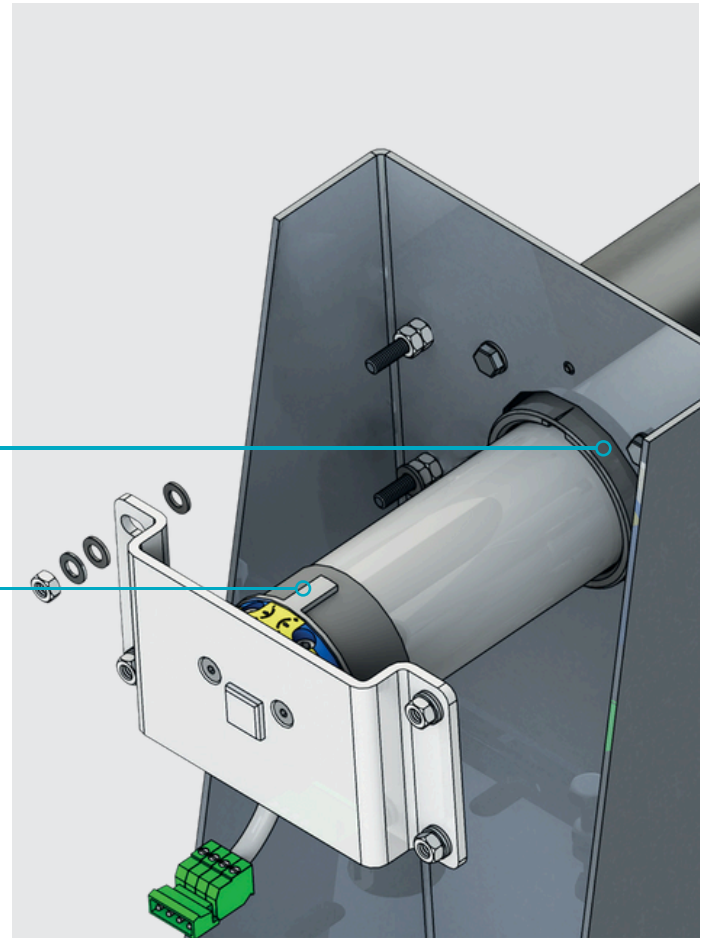

# LED CONNECTION DIAGRAM

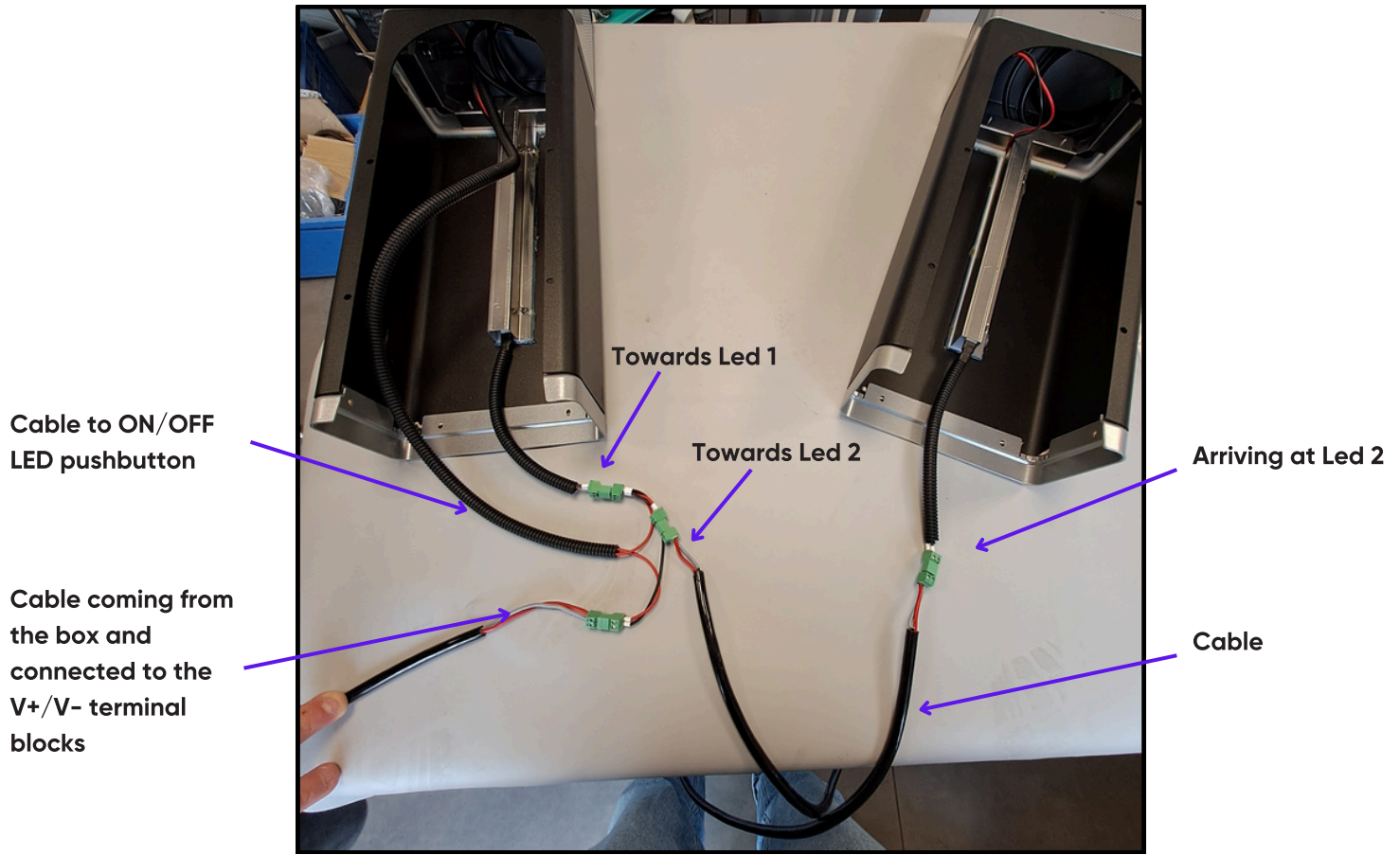

# 1/ The LEDs do not light up or no longer light up.

1/ Check the tension on the V+/V- terminal blocks. It should be around 12VDC.

 If there is no voltage, this means that the LED transformer is defective: it must be replaced.

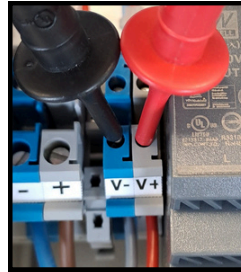

2/ Check that the voltage leaving the V+/V- terminal box arrives at the connector at the bottom of the motor side end-stand.

It should be around 12VDC.

 If there is no voltage, the cable between the box and the bottom of the cover is defective: it must be replaced.

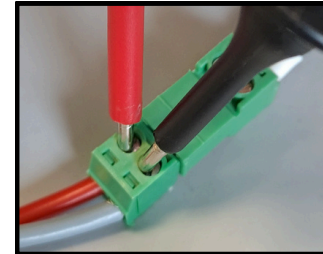

3/ Check the consistency of the connections at the base of the end-stand on the motor side.

- Wire on Terminal Block V+ opposite the red wire
- Wire on V- terminal block opposite black wire

 If necessary, rewire correctly.

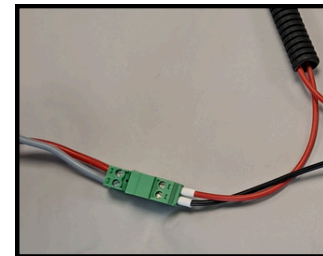

4/ Check the consistency of the connections of the two connectors for LED 1 and 2.

**LED connector 1 (motor side):**

- Red wire opposite red wire
- Black wire opposite black wire

**LED connector 2 (free side):**

- Red wire => cable => red wire
- Black wire => cable => black wire

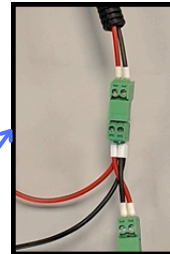
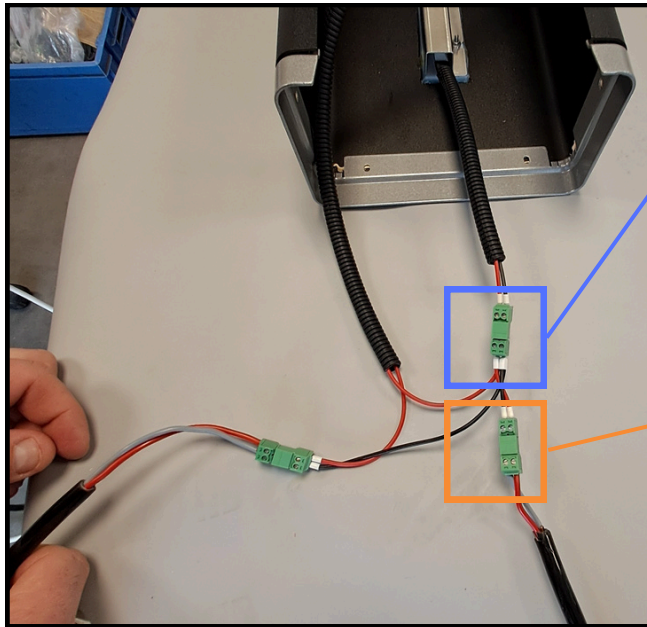

**LED connector 1  
(motor side)**

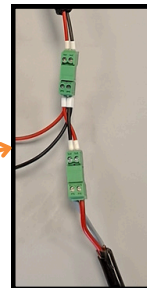

**LED connector 2  
(free side)**

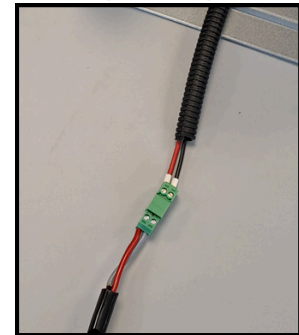

Cable



If necessary, rewire correctly.

5/ Check that there is some tension on each input and output connector.



If there is no voltage, replace the defective element.

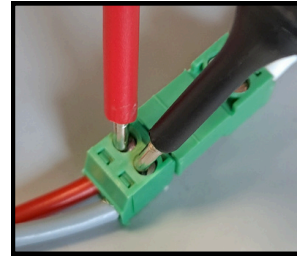

## 2/ One LED is constantly lit and the 2nd operates via the ON/OFF pushbutton

Check that the connector with the wires coming from the box are properly connected to the ON/OFF pushbutton.



Carry out the wiring in accordance with the instructions.

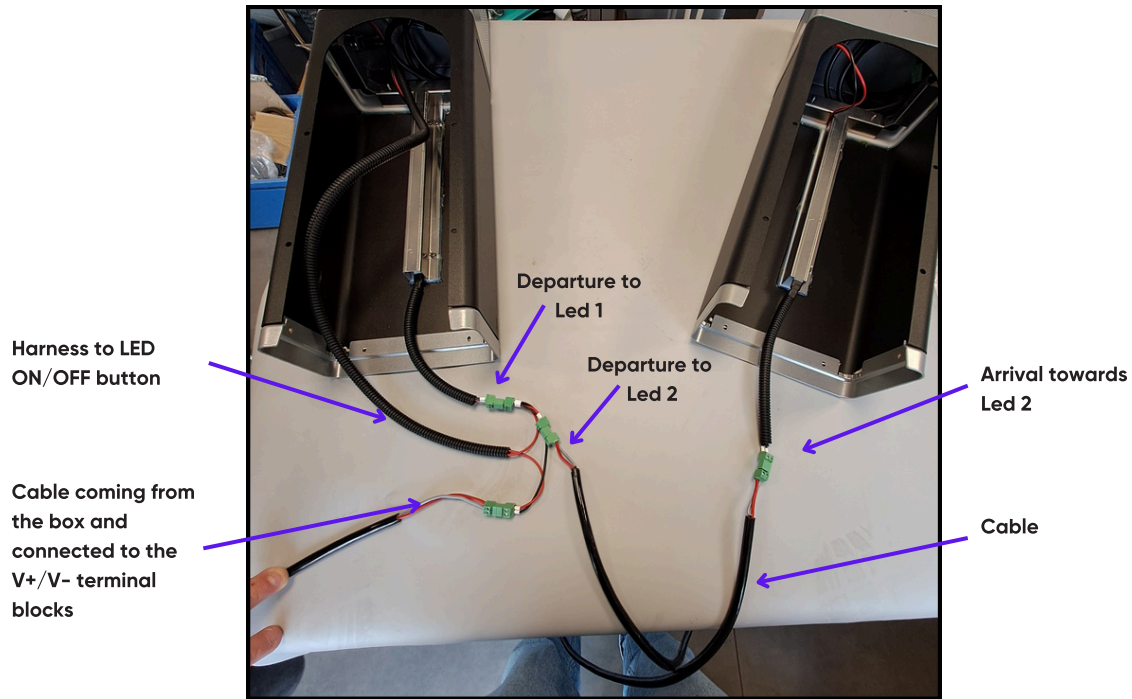

# POOL SOUND WIRING DIAGRAM

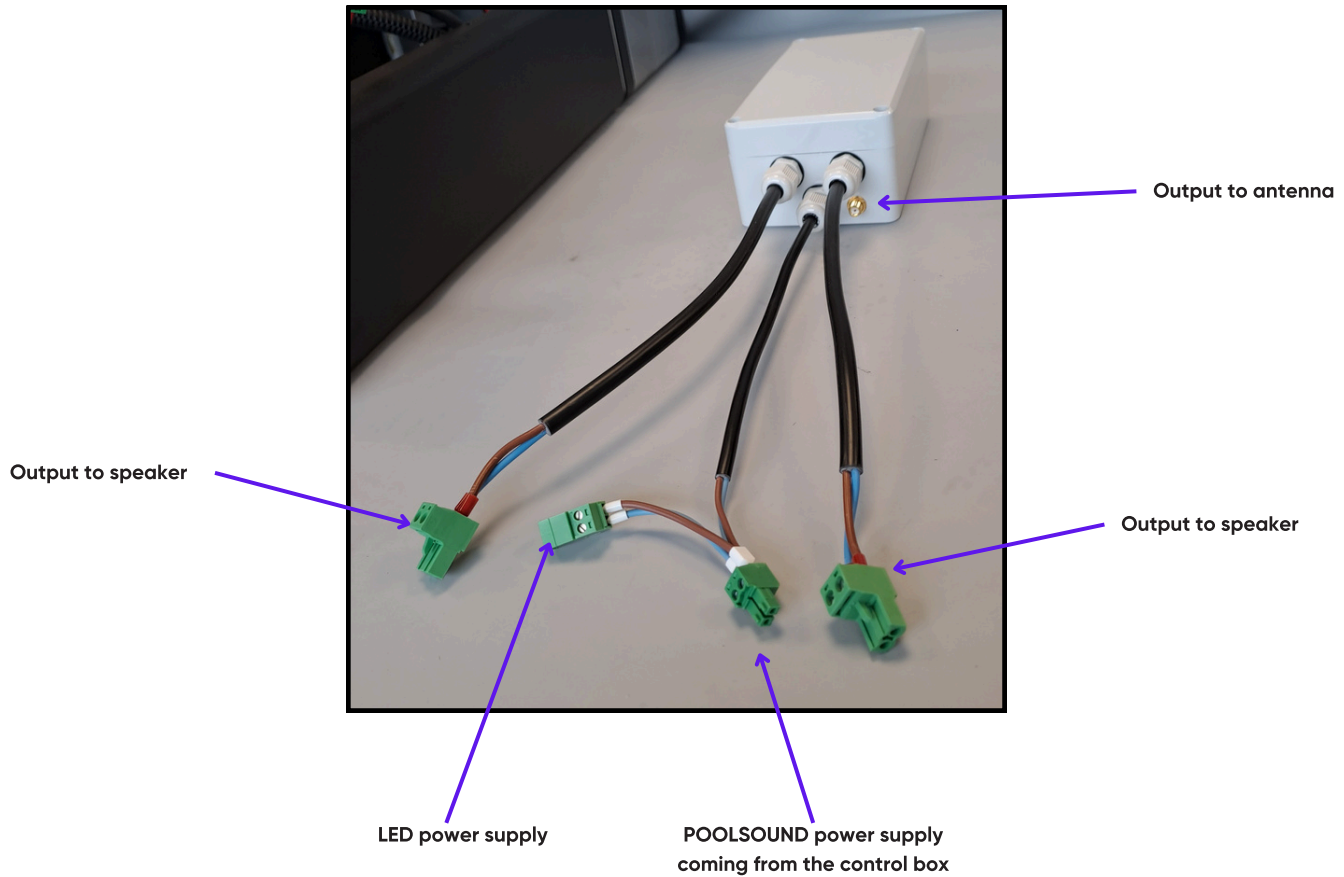

Connect the 1st sound output to the motor side speaker on the motor side connector.  
Then check the consistency of the cable colors (brown versus brown and blue versus blue)



In case of inconsistency, make the correct connection.

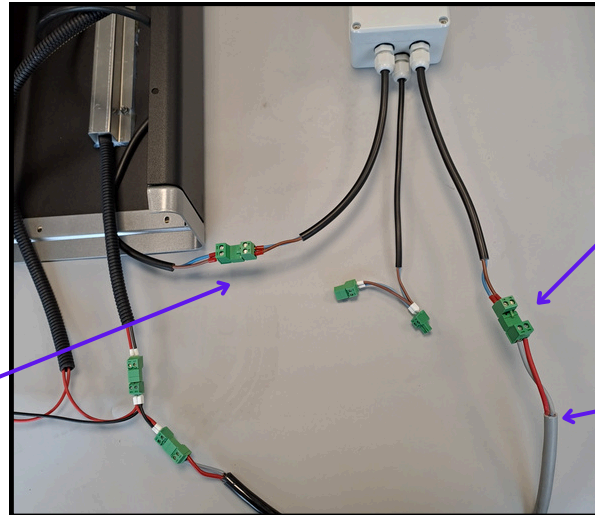

Motor side speaker connector

Free side speaker connector

2x1 mm<sup>2</sup> cable connecting  
the two terminals

Connect the 2nd sound output of the box to the speaker on the free side on the cable previously provided between the two terminals (cable not supplied).

Then check the consistency of the cable colors (brown => 1mm<sup>2</sup> cable => brown and blue => 1mm<sup>2</sup> cable => blue).



If there is any inconsistency, be sure to make the connection correctly.

Disconnect the cable connector coming from the V+/V- terminal box.

Then connect the 1st connector from the Poolsound box to the cable coming from the box then finalize the connection by connecting the 2nd connector to the one leading to the LED power button.

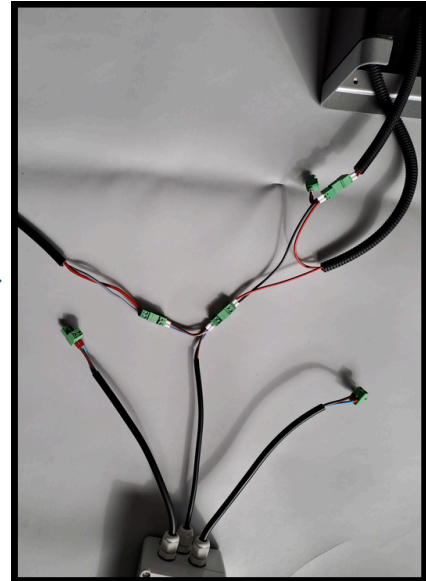
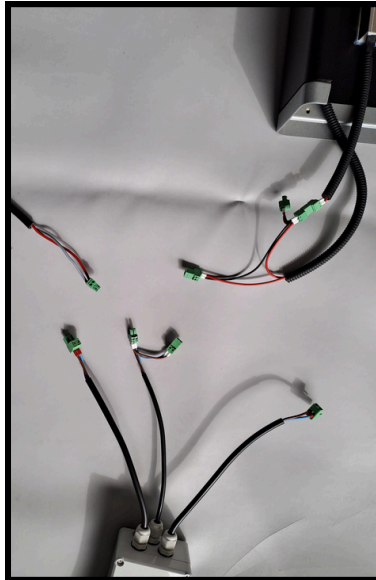
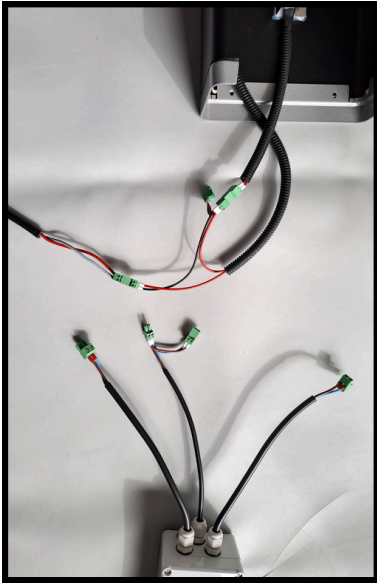

# BLUETOOTH PAIRING PROCEDURE

On your smartphone, activate Bluetooth  while being near the motor side foot.

When searching, the Bluetooth should find the device named TSA3118B



If the Bluetooth network is not found, check the consistency of the connections.

Click on it to connect it.

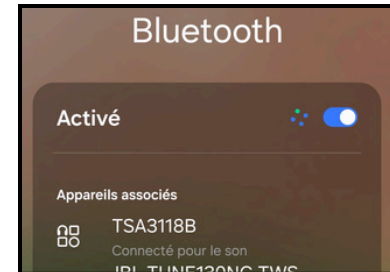
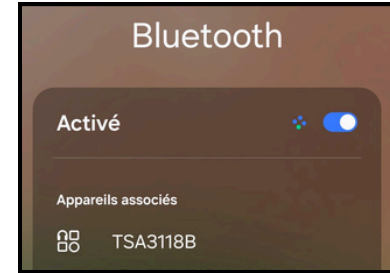



*If you are unable to solve the issue, please reach out to our Technical Support Department.*

**Tel: +33 9 70 72 5000 | [support@cf.group](mailto:support@cf.group)  
ZA La Croix Rouge | 35530 Brécé | FRANCE  
[www.my-cfgroup.fr](http://www.my-cfgroup.fr)**

