

EN



# INSTALLATION GUIDELINES

INSTALLATION/SERVICING/MAINTENANCE/SAFETY ADVICE



DEL 

IN-GROUND POOL COVER

ROLLENERGY EVOLUTION

---

# CONTENTS

## **PLEASE READ THESE INSTRUCTIONS CAREFULLY AND KEEP THEM FOR FUTURE REFERENCE**

Please read this manual carefully to help you understand all of the information and to ensure safe installation, use and servicing. We are not held liable for any damage arising due to a failure to respect the instructions set out in this manual.

DESCRIPTION.....	P.4
Components provided.....	p.4
Tools required for assembly.....	p.6
Packing list.....	p.6
Assembly.....	p.6
INFORMATION.....	P.7
INFORMATION.....	P.8
Prerequisites.....	p.8
To ensure that the cover complies with standard nf p90-308.....	p.9
INSTALLATION.....	P.10
Characteristics and verification of the internal dimensions for cover pit.....	p.10
INSTALLATION.....	P.11
Template.....	p.13
Drilling.....	p.14
Fastening the decks.....	p.15
Installation of the reel system.....	p.16
Fastening the reel system to the decks.....	p.16
Setting the level of the reel system.....	p.17
ensure that the reel system/pool are perpendicular.....	p.17
Beam support.....	p.17
Installing the beam.....	p.19
Middle telescopic support.....	p.19
Installing the counterweights.....	p.19
Installation of the counterweights.....	p.20
Installing the decking.....	p.20
Electrical control box.....	p.21
Wiring of Unibox 120 and 250 control box with Wi-Key command for motor PL 1210, PL 3210. ...	p.23
Wiring of Unibox 120 and 250 control box with key-operated enclosure for motor PL 1210, PL 3210.....	p.24
Wi-Key control.....	p.26
General information / calibrating the limit switches (motor PL).....	p.29
After complete wiring.....	p.30
Programming mode.....	p.31
Automatic mode.....	p.32
SERVICING/MAINTENANCE.....	P.33
INFO Display.....	p.33

# CONTENTS







Intervention and troubleshooting .....	p.36
Water level in pool.....	p.41
Water filtration and treatment .....	p.41
care (responsibility of the customer) .....	p.42
maintenance (once per year minimum) .....	p.43
Wintering .....	p.44
spare parts .....	p.45
Troubleshooting guide.....	p.45
warranty condition .....	p.46
<b>REPAIR .....</b>	<b>P.47</b>
<b>SAFETY ADVICE .....</b>	<b>P.48</b>
<b>RECYCLING .....</b>	<b>P.50</b>
packaging.....	p.50
end of lifecycle .....	p.50

# DESCRIPTION

## COMPONENTS PROVIDED

### PLATE



 <p>Ø12 Sleeve</p> <p>x8</p>	 <p>Ø8.4 Washer x 24</p> <p>x8</p>	 <p>cap</p> <p>x8</p>	 <p>Sleeve</p> <p>x1</p>
 <p>M8x80 Screw</p> <p>x8</p>	 <p>M8 Nut</p> <p>x8</p>	 <p>Washer</p> <p>x8</p>	

Bag of loose fittings

### CONTROL BOX AND COVER CONTROL



### OPTION



# DESCRIPTION

## COUNTERWEIGHTS

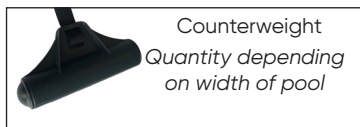

## REEL SYSTEM

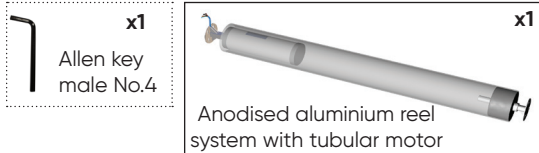

## BEAM SUPPORTS – Model and colour according to order (1 Packing)



## BEAM – Model according to order (1 Packing)

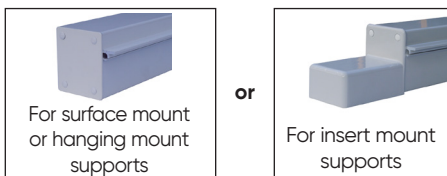

## MIDDLE TELESCOPIC SUPPORT (1 Packing)

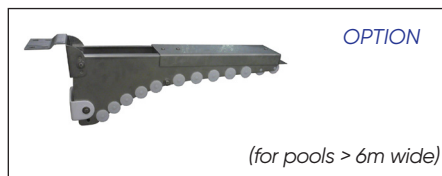

## DECKING – Model according to order (1 pallet)



IPE















Aluminium

# DESCRIPTION

## TOOLS REQUIRED FOR ASSEMBLY



	Meter and decameter
	Level
	Screwdriver
	Perforator
 Ø8/Ø12/Ø20	Concrete drill
	Adjustable pliers
	Angle grinder

 N°13	Pipe spanner 10 - 13 - 17
	Screwdriver T25
	Cutter
	Pencil
	Mallet
 N°10 - 13 - 17	Flat wrench

## PACKING LIST

**Example – for a 5.00 x 10.00m pool with roman stairs**  
 Plates+control box: 1 0.65 x 0.45 x 0.25/40kg Packing  
 Reel system: 1 0.15 x 0.15 x 5.10 m/40kg Packing  
 Beam: 1 0.15 x 0.15 x 5.10m/34kg Packing  
 Beam support: 1 0.30 x 0.20 x 0.20m/10kg Packing  
 Decking: 1 1.20 x 1.00 x 0.50m/100kg pallet  
**Total weight: 230kg**

## ASSEMBLY



**2 persons**



**3 hours**

## INFORMATION

For swimming pools made of concrete, aerated concrete, solid or hollow masonry.

For polyester shell or panel pools, use a concrete belt and sealing blocks to secure the plates and locking kits.

Quantity of concrete (in litres) for 1 plate sealing block:

Pool surface (m<sup>2</sup>)x2.5=X litres of concrete

Open pool: the cover is rolled up into the pit that is covered with decking. These lay on a beam that is fitted into Beam supports that need insert mount or may use hanging mounts or be pegged.

The shaft for the cover is Tubular at a depth of 55cm below the top surface of the pool and is supported by 2 plates that are fastened to the wall.

Power is supplied by an control box located in a technical room.





Limit switches can be set directly on the control box.

Opening and closing control is carried out via a switch located in a place from where the pool can be seen.

The cover is made of articulated waterproof slats that float on the surface of the water.

# INFORMATION

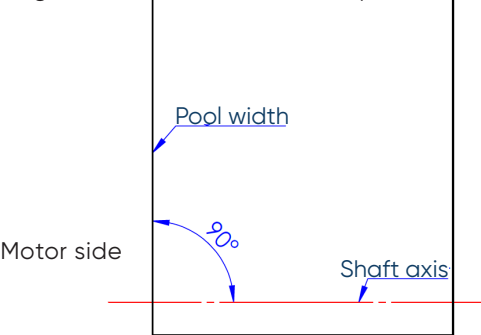
## PREREQUISITES

	<p>The water level must be maintained when the cover is installed. Refer to the maintenance section.</p>
	<p>For the deck to run smoothly, the mast axis must be positioned perpendicular to the length of the motor side of the pool.</p> 
	<p>Power is supplied from an electrical box in the machine room.</p>
	<p>Remember to wear safety equipment.</p>



- **WE ADVISE YOU TO READ ALL THE INSTALLATION STEPS BEFORE FITTING TO AVOID UNNECESSARY HANDLING.**
- **To date, covers with a removable form on a side staircase do not comply with standard NF P90-308.**
- **Unless otherwise specified by the alarm manufacturer, immersion alarms are not compatible with .**
- **On mirror or Infinity pools, DEL covers do not comply with French standard NF P90-308 unless the pool is equipped with a Vitalia Infinity control box to automatically lower the water level by at least 2cm when the pool cover is closed.**

# INFORMATION

## TO ENSURE THAT THE COVER COMPLIES WITH STANDARD NF P90-308

Tubular motor complies with electrical standards

Decking require the use of a tool or force of more than 5kg to be lifted. "The minimum weight per element is 11kg".

Slats. (material complies with ageing resistance requirements set out in standard NF T54 405-1)

Maximum total gap of 70mm between the wall and cover

Separating wall or Sécuriwall

Wi-Key or switch with maintained contact during locking looking at the pool

Control box conform to electrical standards:  
C 15-100  
NF EN 60335  
NF EN 61000-6-3  
NF EN 55014-1

Locking kits activated by a tool or a double action

The diagram shows a pool cover being lowered into a pool. A tubular motor is connected to the cover. The cover is supported by a separating wall. The slats are made of a material that complies with ageing resistance requirements. The decking requires a tool or force of more than 5kg to be lifted. The minimum weight per element is 11kg. The maximum total gap between the wall and the cover is 70mm. The control box conforms to electrical standards: C 15-100, NF EN 60335, NF EN 61000-6-3, and NF EN 55014-1. Locking kits are activated by a tool or a double action.

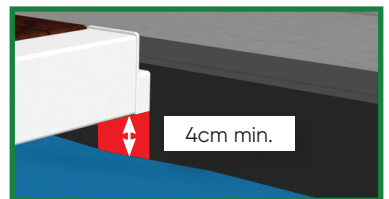
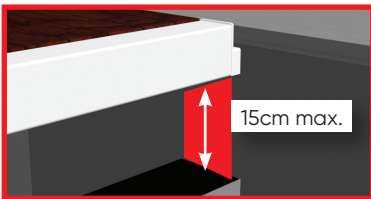

# INSTALLATION

## CHARACTERISTICS AND VERIFICATION OF THE INTERNAL DIMENSIONS FOR COVER PIT

**!** The walls of the housing must be vertical and parallel with each other.

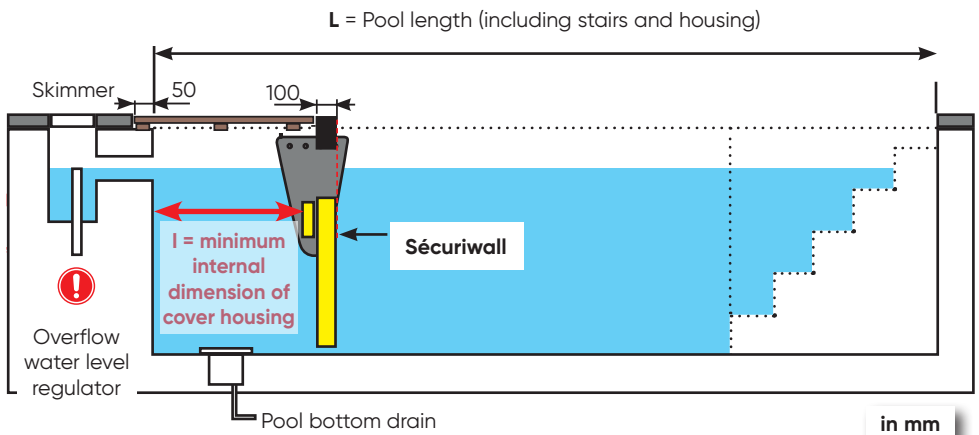
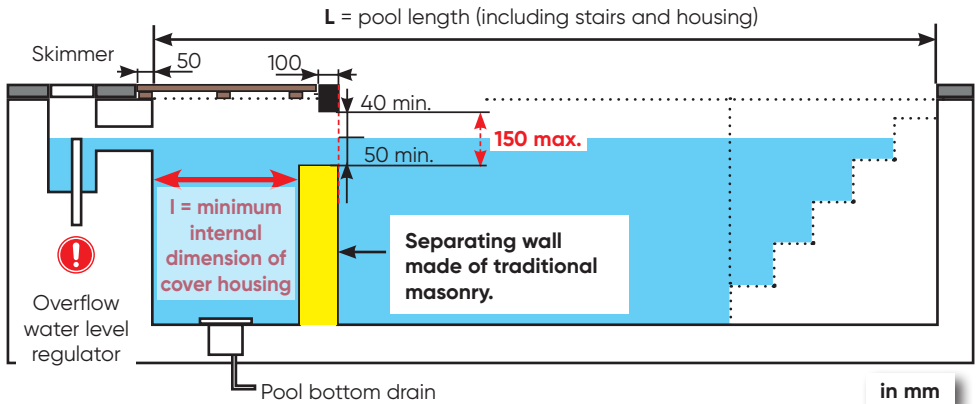

# INSTALLATION

**PLATES**

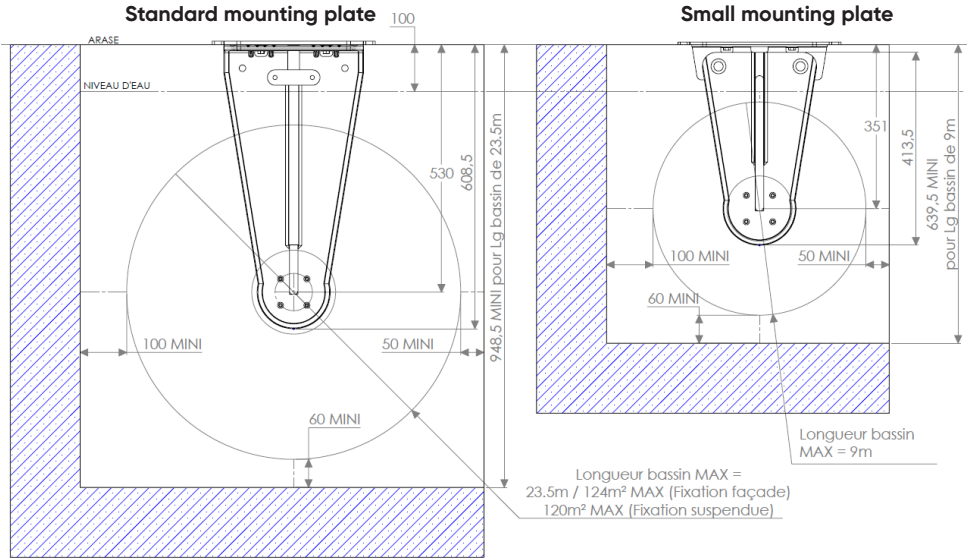

# INSTALLATION

L (in m)	< 6	6 to 7	7 to 8	8 to 9	9 to 10	10 to 11	11 to 12	12 to 13	13 to 14	14 to 15	15 to 16	16 to 17
I (in mm)	548	574	598	621	643	664	684	703	722	740	758	775

Decking  
750mm

Decking  
900mm

L (in m)	17 to 18	18 to 19	19 to 20	20 to 21	21 to 22	22 to 23	23 to 24	24 to 25	25 to 26	26 to 27	27 to 28	28 to 30
I (in mm)	791	807	823	839	854	869	883	897	911	925	938	965

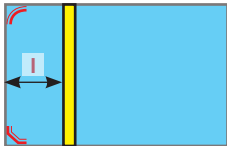

With right angles or shelves and cut-off corners  $\leq 10$ cm behind the pit.

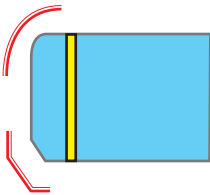

With shelves or cut-off corners  $> 10$ cm behind the pit.

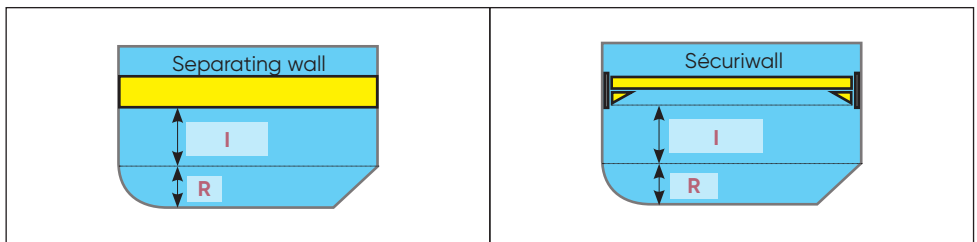

**!** The I measurement (minimum internal dimension of the pit) must be taken from the edge of the shelf or cut-off corner.

# INSTALLATION

## TEMPLATE

### ➤ RIGHT ANGLE

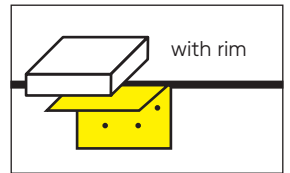
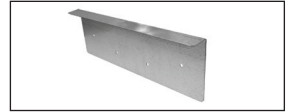
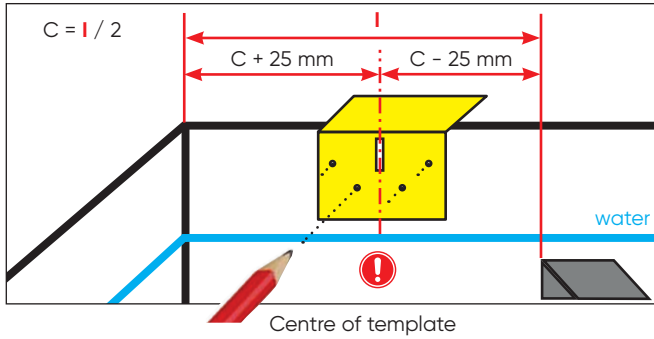

### ➤ SHELVES OR CUT-OFF CORNER WITH BRICK SEPARATING WALL

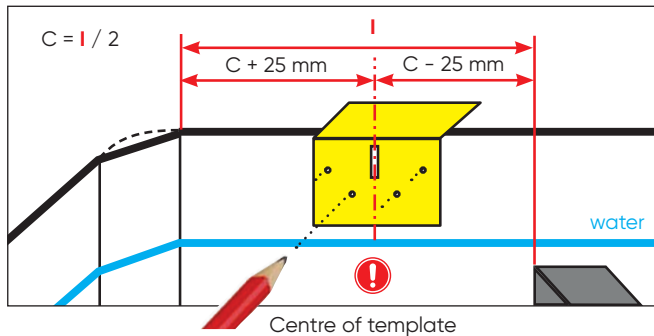

- Carry out the Template for both sides of the pit.
- The deck fastenings must be above the water level.

# INSTALLATION

## ▶ RIGHT ANGLE OR SHELVES OR CUT-OFF CORNERS WITH SÉCURIWALL

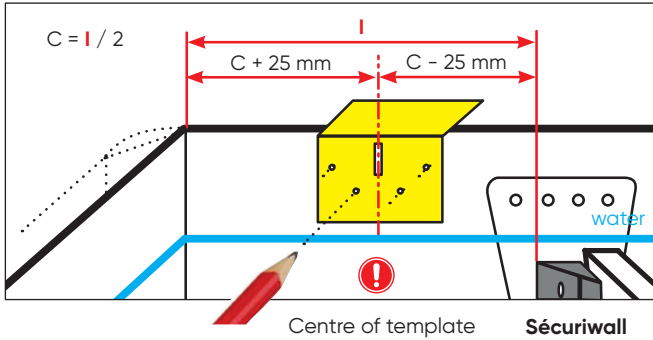

- Carry out the Template for both sides of the pit.
- The deck fastenings must be above the water level.

## DRILLING

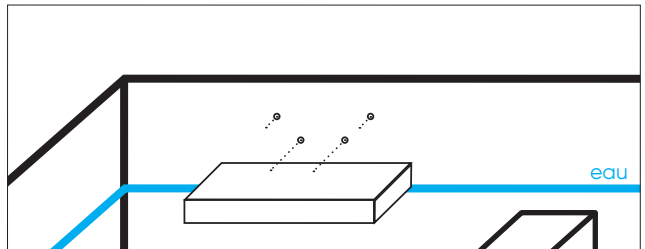
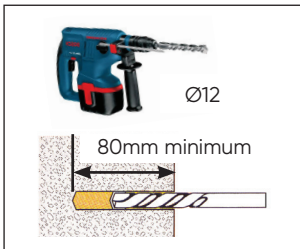







- **Clean the drilled holes well**
- **For pools with water in, put a polystyrene sheet or something similar on the water to contain the dust when you drill.**

# INSTALLATION







## FASTENING THE DECKS

Remember to leave room for the motor Câble to go to the Junction box.

### FAÇADE FASTENING

 x8 Ø12 Sleeve	 x8 M8x80 Screw	 x8 Ø8,4 x 15 Washer
 x1 Câble clamp	 x8 PVC washer	 x8 PVC cap

### HANGING MOUNT FASTENING AS AN OPTION

 x8 Ø12 Sleeve	 x8 Bolt M8 x 90	 x8 Ø8,4 x 8 Washer x 24
 x2 Deck	 x4 wedge	 x4 Bolt

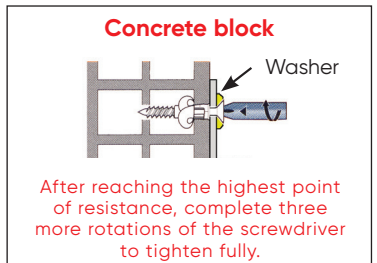
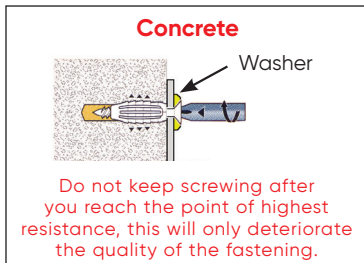
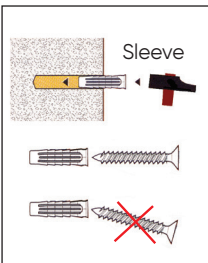
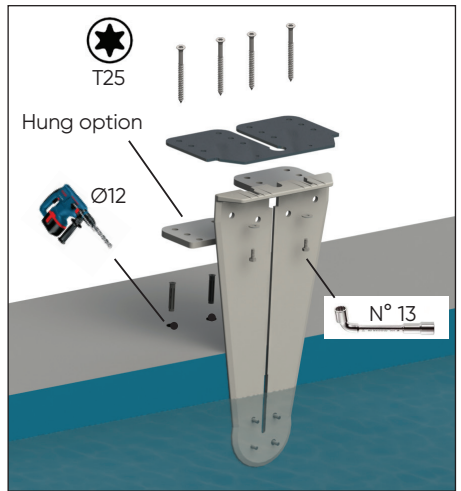
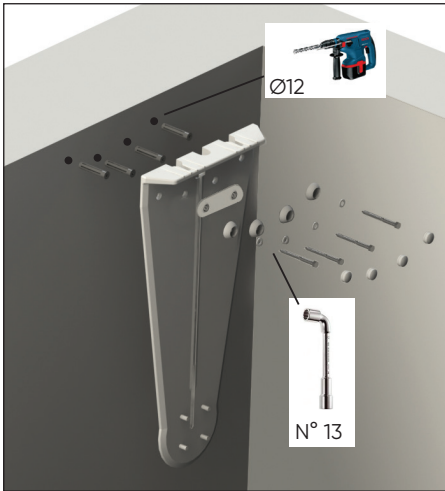

# INSTALLATION

## INSTALLATION OF THE REEL SYSTEM

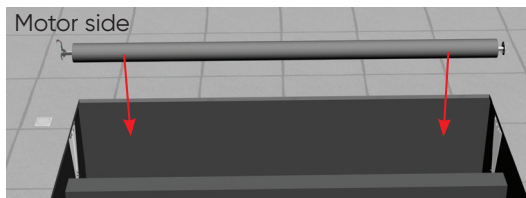

- Do not carry the reel system by holding the motor Câble
- If there is water in the pool, let the reel system fill up with water.
- Test the motor before launching.

## FASTENING THE REEL SYSTEM TO THE DECKS

### MOTOR SIDE

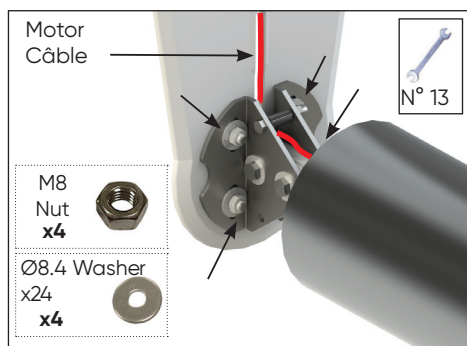

Put the motor Câble into the groove in the deck.

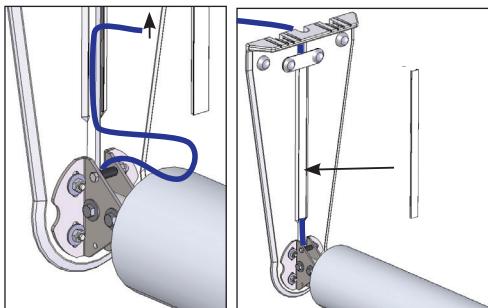

### FREE SIDE

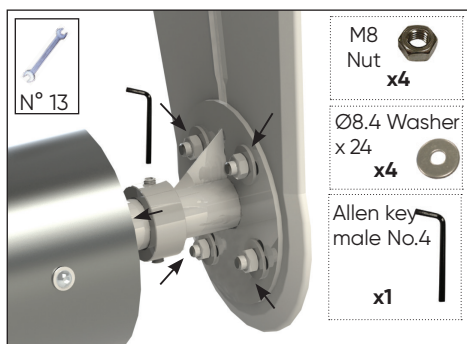

- The decks must be snug with the walls.

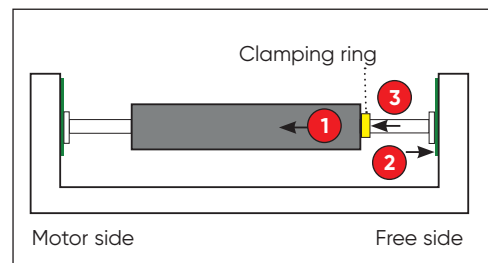

# INSTALLATION

## SETTING THE LEVEL OF THE REEL SYSTEM

! **Motor side**

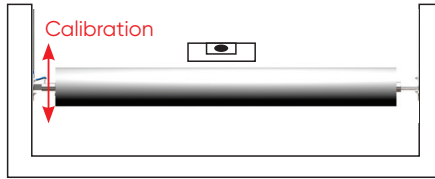

## ENSURE THAT THE REEL SYSTEM/POOL ARE PERPENDICULAR

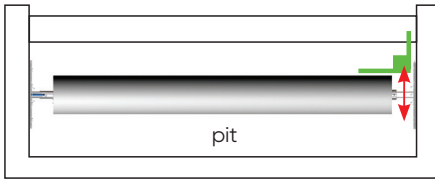

! **Free side**

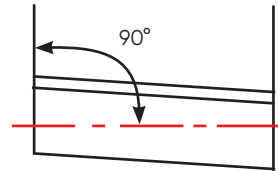

To allow the cover to be rolled out, it is essential for the reel system to be placed perpendicular to the length of the pool.

## BEAM SUPPORT

### ▶ ADJUSTABLE HANGING MOUNT VERSION

For concrete or panel pools

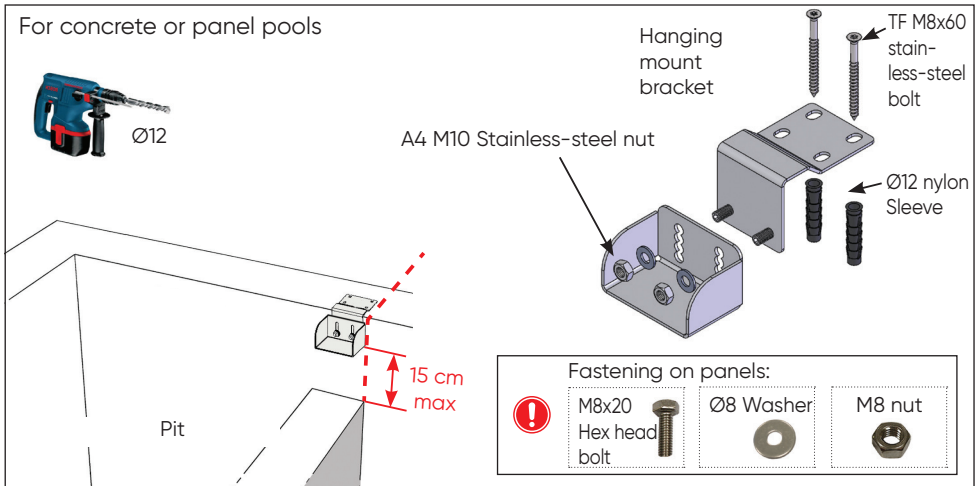

# INSTALLATION

## VERSION INSERT MOUNT

For concrete pools

Pit

15 cm max

Joint 2

Joint 1

Bolt

Flange

Liner

Box insert mount

Stick joint 1 onto the housing before installing the liner.  
Place joint 2, the flange and bolt into place.  
Cut the liner using a Stanley knife.

## PEGGED FAÇADE VERSION

For concrete block and concrete pools, as well as pools whose walls are 8mm thick or more

Pit

15 cm max

Universal Sleeve 12 x 60

M8x80 hex head Screw

Ø8.4x24 Washer

Ø12

80mm minimum

Sleeve

**Concrete**

Washer

Do not keep screwing after you reach the point of highest resistance, this will only deteriorate the quality of the fastening.

**Concrete block**

Washer

After reaching the highest point of resistance, complete three more rotations of the screwdriver to tighten fully.

# INSTALLATION

## INSTALLING THE BEAM

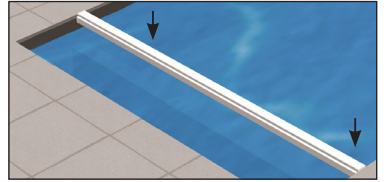
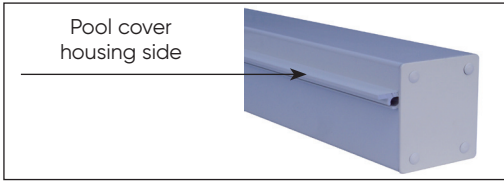

## MIDDLE TELESCOPIC SUPPORT

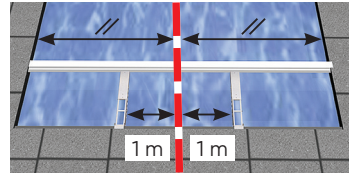
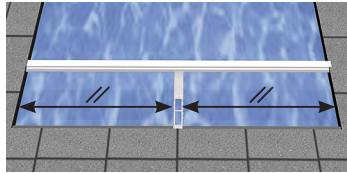
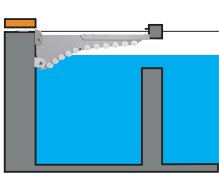

For pools that are more than 6m wide, remember to install 1 or 2 intermediate Beam supports in order to support the centre of the beam (see enclosed leaflet).

## INSTALLING THE COUNTERWEIGHTS

The counterweights ensure that the cover is rolled up correctly by "holding" it against the axis. Lateral movement of the counterweights provides "correction" if the reel system rewinds unevenly in relation to the centre of the pool. The stair counterweight holds the stairs in place, so they do not fall backwards.

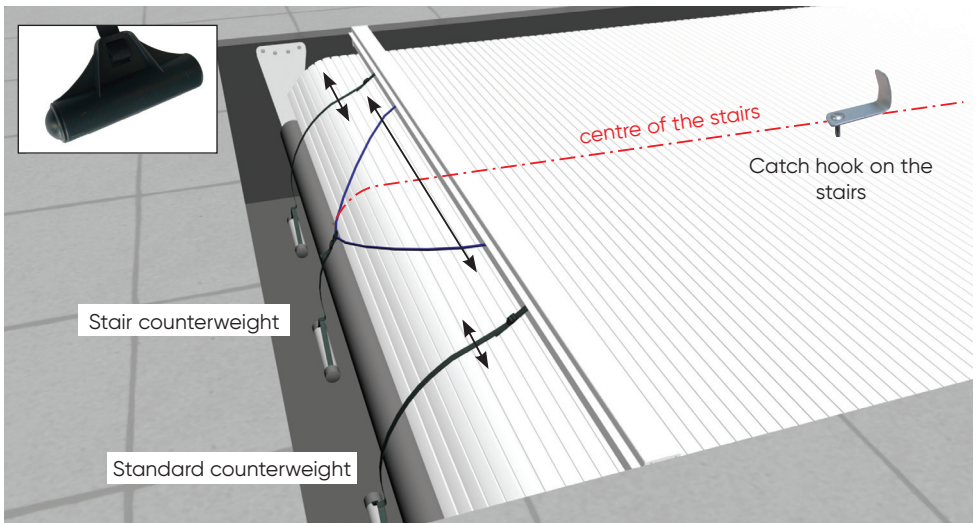

# INSTALLATION

## INSTALLATION OF THE COUNTERWEIGHTS

  
**Adjusting  
depth of  
counterweights**

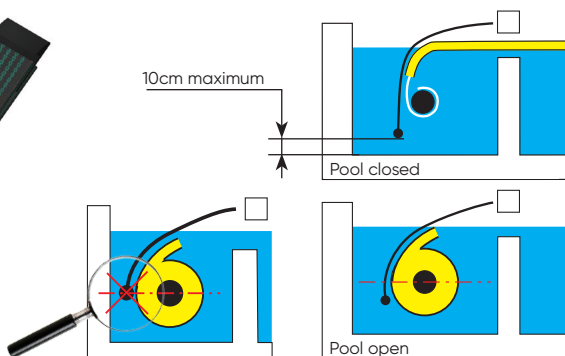

## INSTALLING THE DECKING

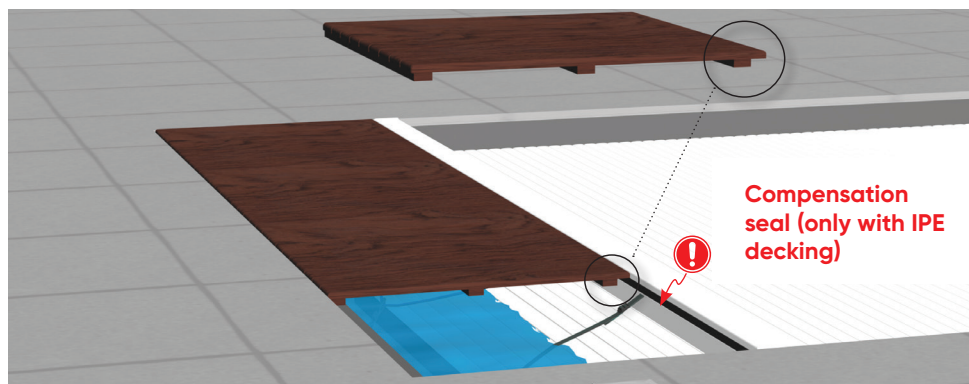

Dimensions must be determined in compliance with the appliCâble standard.

If the decking are not supplied by DEL, you are responsible for their compliance.

The use of decking that do not comply with the standard will de facto render the entirety of the installation non-compliant. In order for the duckboard to comply with standard NF P90-308, DEL recommends that the following instructions must be respected:

- The wood used must be Class 4 and have a minimum lifespan of 3 years. E.g.: Ipe, doussie, merbau, moabi, padauk, or robinia for wood that has not been treated and Scotch pine or maritime pine for treated wood.
- The minimum effort required to lift a duckboard must be 5kg. The minimum weight for each element must be 11kg. Failing this, the decking must be fastened down or only removable by using a tool.
- The maximum space between the boards must be less than 7mm, in order to avoid anything being trapped between them.
- In order to prevent any risk of corrosion, the bolts should be made of A4 stainless steel or equivalent.

# INSTALLATION

## ELECTRICAL CONTROL BOX

### ► MOUNTING THE CONTROL BOX

- The installation must be carried out in accordance with the electrical standards in force in the country of installation; in France in accordance with standard NF-C 15-100 (part 7-702), in Europe in accordance with standard HD 384-7-702 or equivalent in accordance with local regulations.
- The control box must be mounted on a wall in a frost-free technical room, away from rain, sunlight, any source of heat and any risk of it being sprayed or submerged, in an easily accessible location.
- It must be installed level, ideally between 1.2 metres and 1.5 metres above the ground, vertically, with the Câble glands facing downwards and on a wall that is sufficiently solid, flat and smooth to withstand the weight of the control box.
- The control box must be securely fixed to the wall using the screws and plugs supplied.
- Be careful if you decide to fix your control box by any other means, as the guarantee may not apply. Please note that adhesives are not considered a reliable means of fixing.

*Note: Use the mounting template provided with the control box.*

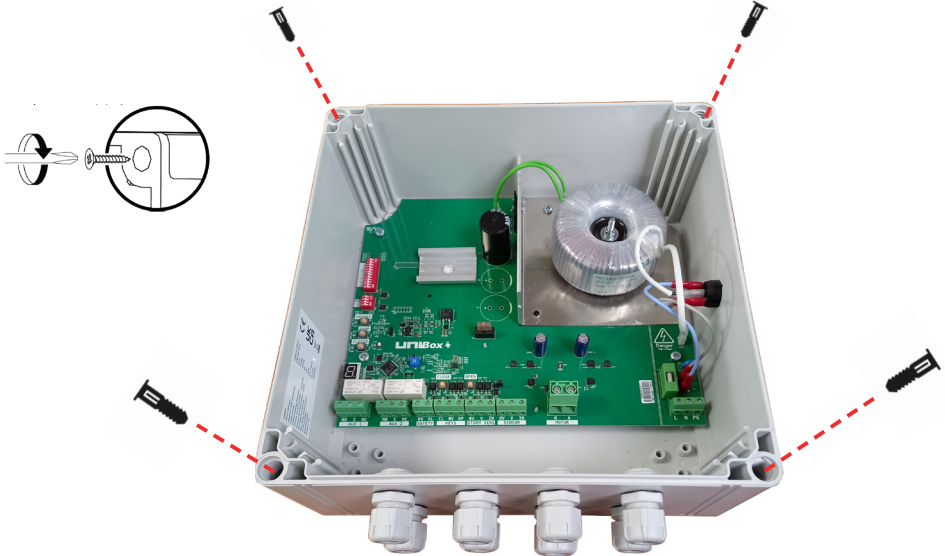

**No warranty if box is drilled.  
If the enclosure is drilled, be sure to seal the fixings.  
Use the fixings supplied with the box to maintain the IP rating.**

# INSTALLATION

The electrical connection of the equipment must only be carried out by a qualified professional, and they must comply with the manufacturer's instructions in addition to the following applicable standards and regulations:

- NF C15-100: Low voltage electrical installations.
- CEI 60364: Electrical installations for buildings.

Please refer to the leaflet enclosed with the control box to ensure correct installation.



Incorrect installation may result in an electric shock, or it may damage the unit. We recommend that you disconnect the control box from the electricity supply prior to any work being carried out on it.

Any specific electrical supply line must be protected by a 30 mA circuit breaker along with a sufficient overcurrent protection control box.

We recommend use of a shielded cable with a nominal cross-section that is not lower than the one indicated in the following table:

Current rating of unit A	Nominal cross-section mm <sup>2</sup>
≤ 0.2	Flat twin tinsel cord a
> 0.2 and ≤ 3	0.5 a
> 3 and ≤ 6	0.75
> 6 and ≤ 10	1.0 (0.75) b
> 10 and ≤ 16	1.5 (1.0) b
> 16 and ≤ 25	2.5
> 25 and ≤ 32	4
> 32 and ≤ 40	6
> 40 and ≤ 63	10

NOTE: For power cables supplied with poly-phase units, the nominal cross-section of the conductors is based on the maximum cross-section of the phase conductors at the end of the power cable that is intended to be connected to the terminals of the unit.

- a These cables can only be used if their length, as measured between the point where the cable or cable protector enters the equipment and the connection to the mains supply, does not exceed 2 m.
- b Cables that have the cross-section indicated in brackets can be used for mobile units if their length does not exceed 2 m.

# INSTALLATION

## WIRING OF UNIBOX 120 AND 250 CONTROL BOX WITH WI-KEY COMMAND FOR MOTOR PL 1210, PL 3210.



- Ensure that there is no one in the pool during the maneuver.
- All connections must be made with the power off

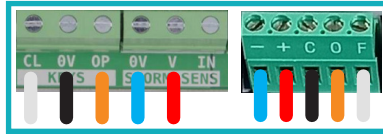

\* and \*\*  
see comments and  
diagrams on page 23

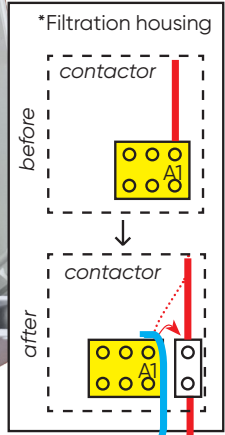
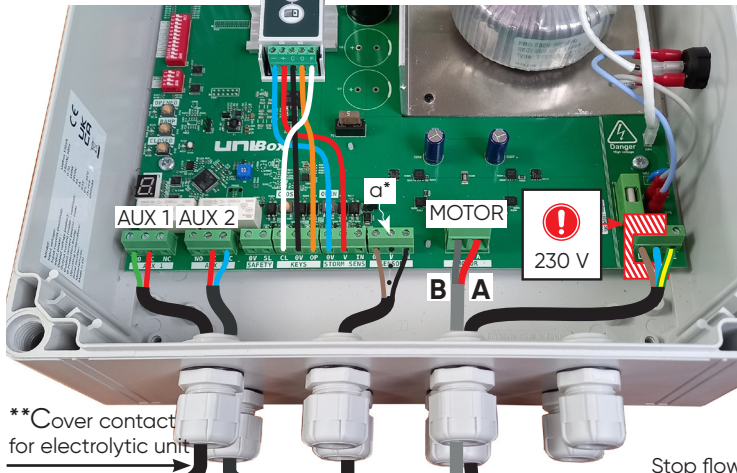

\*\* Cover contact  
for electrolytic unit

Stop flow

NC  
C

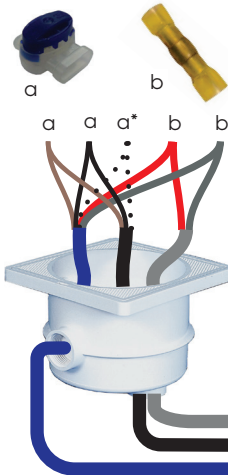

30mA residual circuit breaker

(not supplied)

Connection  
Socket **P / N / E**

**230 Volts**

**Single-phase 50Hz**

2 x 6mm<sup>2</sup> - 0 to 25m  
2 x 10mm<sup>2</sup> - from 26 to 50m

limit switch Câble

motor Câble

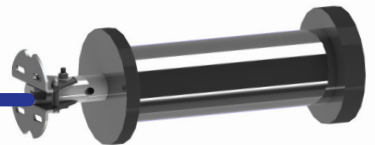

PL 1210 / PL 3210

# INSTALLATION

## WIRING OF UNIBOX 120 AND 250 CONTROL BOX WITH KEY-OPERATED ENCLOSURE FOR MOTOR PL 1210, PL 3210.



- Ensure that there is no one in the pool during the maneuver.
- All connections must be made with the power off

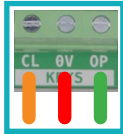

\* and \*\*  
see comments and diagrams on page 23

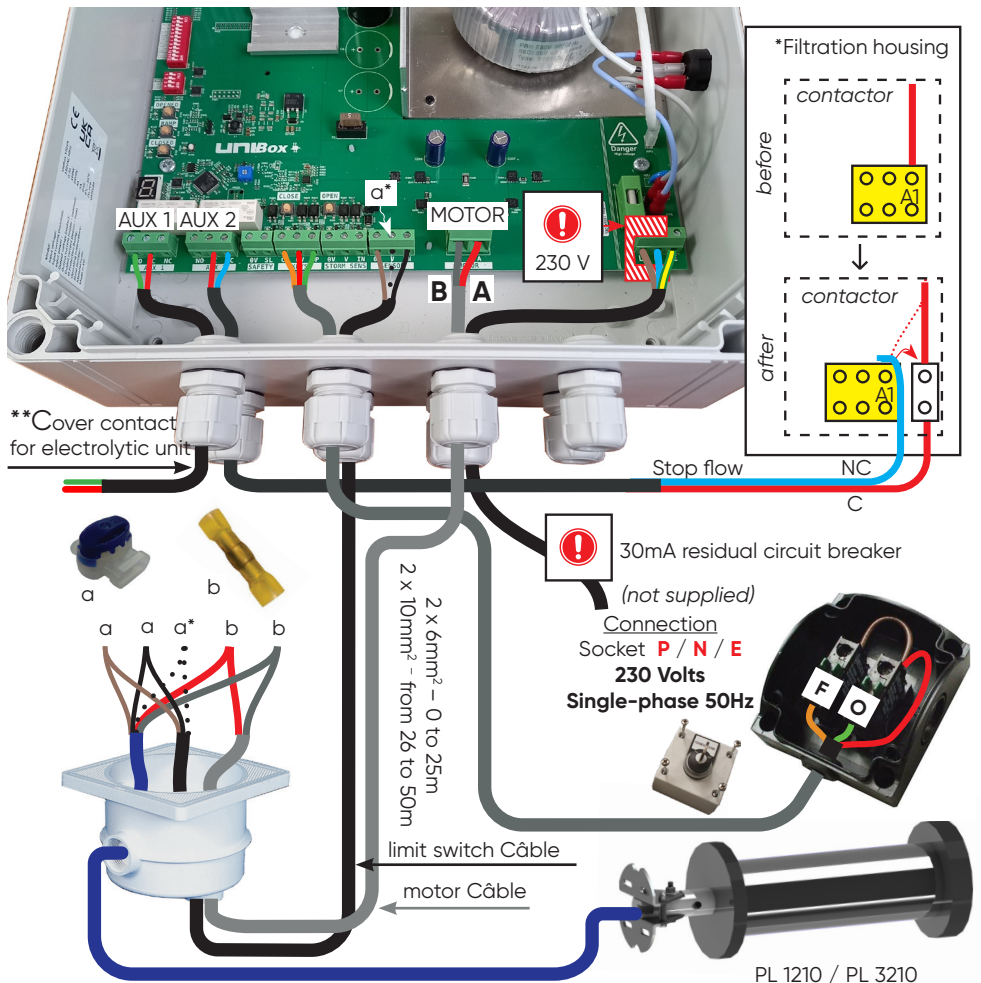

# INSTALLATION

\* "AUX2 terminal block Piloting the filtration pump.

When the cover is moving: Contact C-NC open (stop filtration) and contact C-NO closed (filtration).

Filtration control box :



\*\* "AUX1" terminal block electrolyser control

Closed: Contact C-NO closed and contact C-NC open

Open: Contact C-NO open and contact C-NC closed

The position of the dry contact is saved in the memory in case power to the control box is ever switched off.

α\* : ..... Wire may or may not be present according to the type of motor.

Motor connection according to sensor type

2-wire motor sensor  
(mechanical sensor)

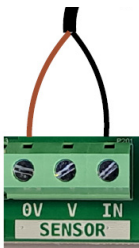

3-wire motor sensor  
(inductive sensor)

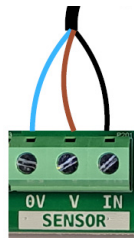

**Remember to change jumper pinout.**



Its location must allow you to check that no-one has entered the pool during the operation.





**We advise you to put some waterproofing gel in the Junction box once the wiring is completed.**

# INSTALLATION

## WI-KEY CONTROL



Flashing red/green = emitter locked  
See emitter unlocking procedure page 24

	 Receiver	 Emitter
Manufacturer	DEL	DEL
Reference	Wi-Key receiver	Wi-Key emitter
Category	3 (NF EN 300220-1)	3 (NF 300220-1)
Range	50m open field range	50m open field range
	25m through a concrete wall	25m through a concrete wall
Power supply	12 to 48Vcc 30mA max	2 batteries 1.5V AAA
Protection rating	IP40	IP54

The emitter must be set outside the volume 0 position.  
(volume 0 is the part that is underwater, even temporarily).

The distance between the emitter and the receiver must not exceed:

- 50m open field range.
- 25m behind a single wall.
- 15m behind multiple walls or a particularly thick wall.

Frequency bands used by the emitter-receiver: 868MHz to 868.6MHz

Maximum power of the radiofrequency: 10mW

We advise you to check the emitter receiver connection prior to fastening into place.

# INSTALLATION

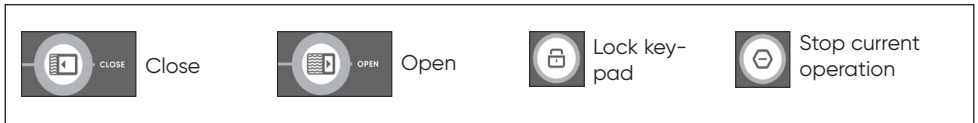
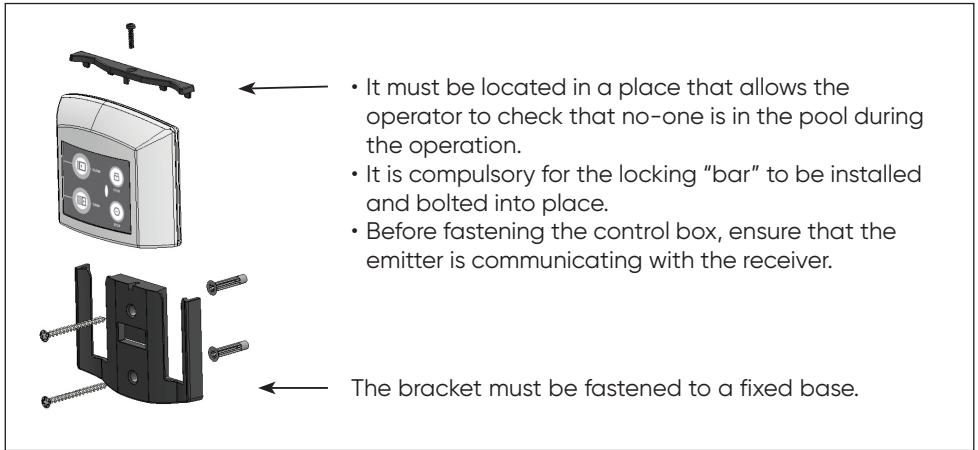

## CONNECT A NEW EMITTER

### Receiver

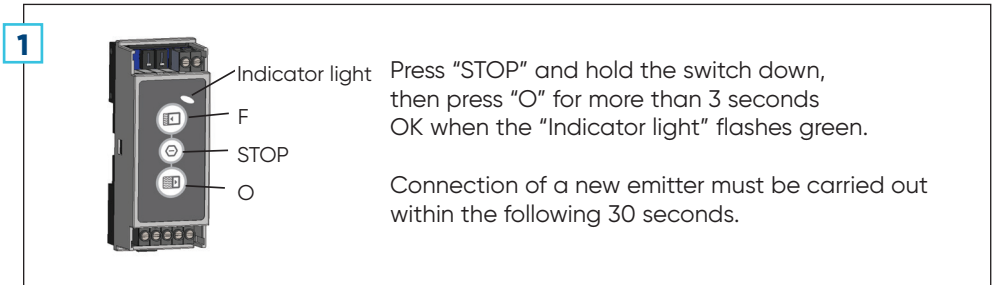

# INSTALLATION

## Emitter

2



Press "STOP" and hold the switch down, then press "O" for more than 3 seconds OK when the indicator flashes red/green

Connection of a new emitter must be carried out within the following 30 seconds.

### LOCK WI-KEY

- Press  for more than 3 seconds until the indicator flashes





 = **system locked**

### UNLOCK WI-KEY

- Press  and keep pressing
- At the same time: press successively on the following 3 switches:



- The  indicator light remains on  = **emitter unlocked**

	Green LED	--->	Wi-Key unlocked
	Flashing green/red LED	--->	Wi-Key locked
	Orange LED	--->	Battery level low
	Red LED	--->	Batteries need to be changed (2xLR03)

# INSTALLATION



**Any person carrying out work on the electrical parts must be qualified and wear PPE (personal protective equipment): gloves, goggles, mat, etc...**



**Warning: use of the pool cover control switches present in the housing (Wi-Key receiver) must only be carried out by a person who is absolutely certain that there is no risk and that no-one will enter the pool during the operation.**

## GENERAL INFORMATION / CALIBRATING THE LIMIT SWITCHES (MOTOR PL)

The power-on is done via the illuminated switch on the side of the electrical cabinet. As soon as the power is turned on, the switch lights up. You can check the initialization of the electronic board on the INFO display for a few seconds.

The electrical cabinet is designed for a maximum of 10 minutes of continuous operation. Beyond that, allow 30 minutes between operations. In case of overheating of certain components, the board enters self-protection mode and stops powering the motor until it cools to a safe temperature.

The operating range of the electrical cabinet is between 0°C and 50°C maximum.

Three operating modes are available and should be well understood by the installer.

**AUTOMATIC MODE:** This is the normal usage mode of the board when all programming has been done correctly. Advanced functions can be enabled, and alarms are active.

**FORCE MODE:** This is the typical mode for maintenance operations. Once entered into force mode, all configurations (limit switches, measured current levels, etc.) are overwritten, and the operator uses the motor without limit switches. This mode should be used with great care. It can also be used in case of sensor failure.

**PROGRAMMING MODE:** This is the mode that allows the operator to record the fundamental parameters for using the board in AUTOMATIC MODE. You enter PROGRAMMING MODE when you need to configure limit switches and the end of the speed ramp. In this mode, advanced functions are not active, as well as some alarms.

**NOTE:** For activating advanced functions, once the corresponding switch is activated, you will always need to restart the board using the illuminated power switch. This operation requires re-reading the parameters and active functions.

# INSTALLATION

## AFTER COMPLETE WIRING

### ▶ CHECK THE DIRECTION OF THE COVER MOVEMENT INSIDE THE CONTROL BOX

To perform this check, use the FORCING mode by activating the dip-switch "FORCED." This operation is very important and should be extended to any potential control devices for the cover, such as remote controls, smartphone receivers, etc.



Verify that the cover opens the pool for swimming when pressing the OPEN button and closes when pressing the CLOSE button.

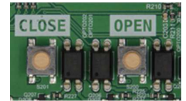

- If it's OK, deactivate the FORCING mode by deactivating the dip-switch "FORCED"



- If not, swap the two power wires at the motor terminal block and check the proper operation; then verify the wiring of the key switch on the terminal block.



**!** Only wire the key switch after checking the correct direction of movement by pressing the OPEN and CLOSE buttons.

### ▶ CHECK THE DIRECTION OF THE COVER MOVEMENT WITH THE CONTROLS

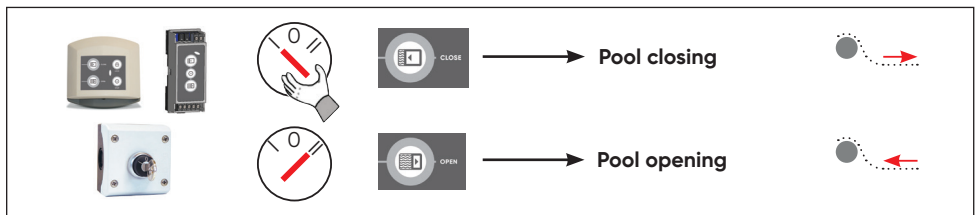

**!** If the control logic is not followed, check the Open / Close wiring of the control

# INSTALLATION

## PROGRAMMING MODE

### ▶ LIMIT SWITCH PROGRAMMING

The limit switch programming must be done with full visibility of the pool.



**NEVER USE REMOTE CONTROLS OR RADIO DEVICES FOR SETTING THE LIMIT SWITCHES.** The procedure must be carried out with the key switch or with the "OPEN" and "CLOSE" buttons on the board.

1. Check the direction of the cover movement (for more information, refer to the specific chapter above).
2. Press the "OPENED" button and hold it until the green LED next to it lights up. You have entered the "open" limit switch programming mode.
3. Set the cover to the rolled-up position (fully open).
4. Wait at least 5 seconds, then press the "OPENED" push button - The green LED turns off and the position is saved.
5. Press the "CLOSED" button until the green LED next to it lights up. You have entered the "closed" limit switch programming mode.
6. Set the cover to the unrolled position (fully closed). Ensure that no one is using the pool beforehand.
7. Wait at least 5 seconds, then press the "CLOSED" push button - The green LED turns off and the position is saved.

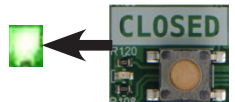
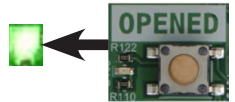

Now the limit switches are programmed, and the board operates in "AUTOMATIC" mode.



[https://youtu.be/db-UT25Fj\\_4](https://youtu.be/db-UT25Fj_4)



# INSTALLATION

## AUTOMATIC MODE

This mode allows the opening and closing of the cover during normal use, with automatic stop at the end of travel.

The cover is controlled in opening or closing by various control devices (switch, wall remote, keychain remote, etc.). The cover is automatically stopped at the pool ends by the previously programmed distance (see programming mode).

When the cover is at one end of the pool, you will not have a choice of movement direction; one direction temporarily becomes invalid: the closing direction will not work when the cover is in the fully closed position, and vice versa, the opening direction will not work when the cover is in the fully open position (see manual mode to override the programmed distance if needed).

All alarms are activated as well as any advanced functions selected by the user.

# SERVICING/MAINTENANCE

## INFO DISPLAY

The INFO display shows any alarms that allow the operator to detect and correct anomalies.

If two alarms are present at the same time, the display will show them in rotation, one after the other.

The acknowledgment of alarms is done using the motor control device (key switch or remote control); by pressing the device twice in the same direction, the alarm will be acknowledged, and the motor can then be restarted.

The list of alarms is as follows:

0	FIXED	Board startup error
1	FIXED	Limit switch programming error
2	FIXED	The motor is not wired
3	FIXED	Faulty sensor
4	FIXED	Blown fuse
7	FIXED	Anti-tear alarm activated; check the straps
8	FIXED	Motor overload
d	FIXED	Major fault on the motor drive

## ▶ CURRENT MONITORING

The current monitoring allows triggering a current threshold alarm and stopping the motor if an anomaly or blockage occurs during pool opening or closing. To ensure the function activates properly, it is necessary to perform a learning procedure for current values; this acquisition must be done in both operating directions of the motor, as for submerged motors, the load differs significantly between opening and closing.

Note: Current monitoring must be activated last. If other functions are modified afterward, current monitoring must always be reprogrammed.

You must therefore carry out the following procedure:

1. Fully open the pool.
2. Set switches 1 and 2 to "ON" to temporarily activate pulse mode.
3. Select the correct current threshold for triggering the alarm using switches 7 and 8 (see figure at the end of this procedure).
4. Restart the control board using the main switch.
5. Check that the message "A" appears on the "INFO" display; this indicates that the function has been activated but an initial acquisition is required to complete the configuration.
6. Make sure no one and nothing is in the water; fully close the pool using the control without interrupting or disturbing the motor's movement. An upside-down "A" will appear on the "INFO" display, indicating that acquisition is required in the opposite direction.
7. Fully reopen the pool using the control without interrupting or disturbing the motor's movement.
8. If the acquisition was successful, the "INFO" display will show notification "B", which means the function is now active. If the data is incomplete or the procedure was interrupted, the display will show notification "C".
9. If alarm "C" is active, the operator must set switches 7 and 8 back to OFF and restart the board to cancel the programming. Then the procedure can be restarted from the beginning for a second attempt.
10. Do not forget to return switches 1 and 2 to their original configuration after the activation of the amperometric control.

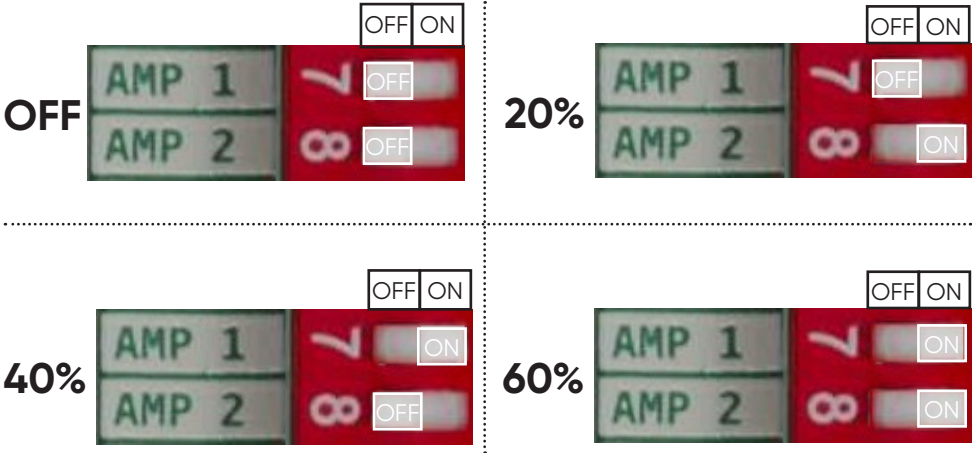

# SERVICING/MAINTENANCE

Threshold values configuration via dip-switches 7 and 8



# SERVICING/MAINTENANCE

## INTERVENTION AND TROUBLESHOOTING

-  **To be carried out only by qualified personnel.**
-  **Before any intervention on the control box and after cutting off the power supply upstream of the box, wait 15 seconds for the capacitors to dissipate their residual energy.**
-  **In case of malfunction of the control box or interventions other than the programming mode, manual mode, or pairing, activate the electrical separation device upstream.**

## DIAGNOSTIC TABLE

DETECTED PROBLEM	ALARM CODE	TROUBLESHOOTING ACTION
When activating the main switch, the control box does not start		Check the wiring to the power supply. If the wiring is correct and single-phase current is present, check the ceramic fuse on the power supply input. If the error persists, replace the entire control box.
When activating the main switch, the initialization sequence ends with an alarm	0	Turn off the board and restart it. If that does not work, perform a restart with the forced mode activated, which will overwrite the data. If the error persists, replace the entire control box.
After the first startup, the board starts correctly, the motor wiring is correct, but the motor cannot be activated	No Action	Put the board in forced mode to overwrite any previously saved settings; reprogram the limit switches. Without programming, the motor can only move if forced mode is active or if the limit switch "open" programming has begun.
During the limit switch programming, alarm 1 is activated	1	This alarm informs the user that the end of travel position has been exceeded. If there is no real reason for this issue, activate FORCED mode to overwrite the old values and then reprogram the limit switches. Acknowledge the alarm.

## SERVICING/MAINTENANCE

DETECTED PROBLEM	ALARM CODE	TROUBLESHOOTING ACTION
During the course end programming or normal use, alarm 2 is triggered	2	The motor power Cables (red and gray) are not properly connected to the control box, or there is a wiring issue between the motor and the control box. Carefully check the wiring to resolve the issue. You can switch to forcing mode to check if the motor is correctly connected. If there's no solution, the motor might be broken or short-circuited. Try powering it with batteries for a final confirmation or connect the motor directly to the control box without any intermediate wiring.
The display shows alarm 3 during motor operation, causing it to stop; the motor doesn't start, and alarm 3 is displayed	3	This alarm is triggered if more than 3 seconds pass between two pulses from the sensor. First, check the sensor wiring. If there are no wiring issues, switch the board to FORCING mode and check if the motor runs at normal speed when operated manually. In this case, the internal sensor in the motor is broken and must be repaired by UNICUM. Until the replacement intervention, the cover can be used cautiously in forcing mode.
The motor doesn't start, and alarm 4 is displayed	4	One of the fuses has blown; turn off the board completely and wait about 15 seconds. Disconnect it from the power supply. Disassemble and check the different fuses with a tester, and replace the faulty fuse. Restart the board and check the motor's proper functioning.

## SERVICING/MAINTENANCE

DETECTED PROBLEM	ALARM CODE	TROUBLESHOOTING ACTION
The motor stops and alarm 7 is displayed.	7	The anti-tear function is active, and a current threshold breach was detected during the first few seconds of opening the cover. Check the straps and ensure no obstacles are preventing the motor from advancing. Acknowledge the alarm. If the alarm reactivates, set the option switch to OFF.
The motor stops and alarm 8 is displayed.	8	The motor is overloaded and has been stopped to prevent damage. This alarm is triggered when the time between two pulses from the sensor is greater than 3 seconds and a high current value is measured. Acknowledge the alarm and analyze the situation to find the cause that triggered the alarm.
Activating a function with the appropriate dip-switch does nothing.		To fully activate advanced optional functions such as the safety loop or impulse mode at opening, you must always reset the board by turning it off and then turning it back on.
The motor stops suddenly.	d	The drive controlling the motor has suffered an electrical shock and may be damaged. If the alarm persists after acknowledgment, the defective board must be replaced.

# SERVICING/MAINTENANCE

## FUSE REPLACEMENT



Replace the fuses with the control box completely powered off. Failure to follow this safety standard poses a high risk of electric shock. This operation must be carried out by trained and qualified personnel.

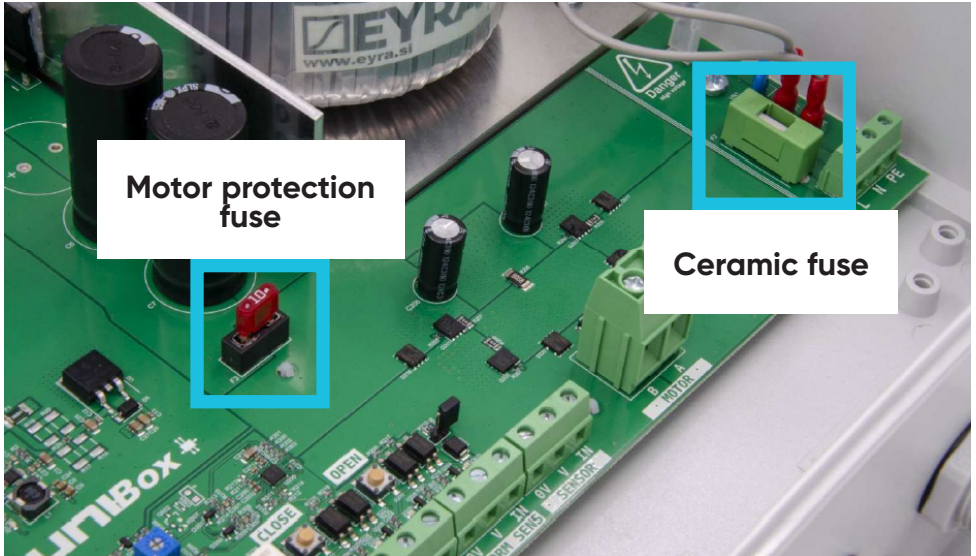

Motor Protection Fuse:

- 10A for Unibox 120VA and 250VA.
- 15A for Unibox 450VA.

## COMPLETE RESET OF THE ELECTRONIC BOARD

To completely erase the memory of the electronic board, follow these steps :

1. Turn all the dip-switches for advanced functions to OFF.

2. Set the FORCED dip-switch to ON

3. Then, turn the dip-switch to OFF.

4. Restart the board.

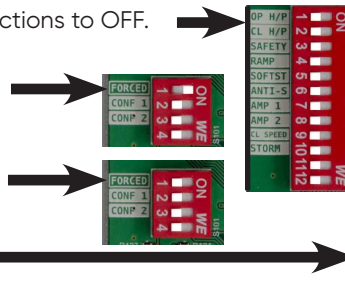

# SERVICING/MAINTENANCE

## ▶ MOTOR CONTROL FROM THE CONTROL BOX DURING MAINTENANCE

**!** The use of these buttons is strictly prohibited without visibility of the pool.

During maintenance and troubleshooting, it is possible to control the movement of the motor directly from the control box; this usage method is not allowed if the pool is not directly visible and cannot be monitored during the movement of the cover.

The "OPEN" and "CLOSE" buttons allow you to open or close the cover at any time, even in the absence of a key-controlled controller.

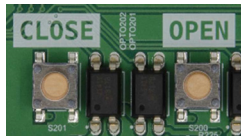

## SERVICING/MAINTENANCE

**Any person carrying out work on the electrical parts must be qualified and they must comply with the manufacturer's instructions in addition to the applicable standards and regulations.**



**During any intervention, the technician must wear PPE (personal protective equipment): gloves, goggles, mat, etc...**

**We recommend that the installation be disconnected from the power prior to any intervention taking place.**

### WATER LEVEL IN POOL

- In order to ensure maximum safety and correct operation of the rewinder, always check that the water level in the pool remains constant and complies with the manufacturer's requirements (for greater comfort, use an overflow and a water level regulator).
- A water level that is too high is due to the overflow being obstructed by leaves or other items.
- A water level that is too low means that there is a risk of blockage.
- In case of a recess or a handrail, the water level must be controlled by a level regulator.

### WATER FILTRATION AND TREATMENT

- Programme filtration to take place at a time when the sun is shining on the pool and ensure that it is set to work all the time when the water reaches 25°C.
- In order to ensure that your installation will last, the water in the pool must be correctly treated in compliance with the applicable standards and recommendations (NF EN 16713-3).
- The pH, hardness and alkali levels of the water must be checked and adjusted as often as is necessary (although you will need to ensure that you don't correct these three parameters independently of each other but do so using the Taylor table and provide the water with balance with regard to the three parameters analysed).

## CARE / MAINTENANCE

### CARE (RESPONSIBILITY OF THE CUSTOMER)

- Clean your slatted cover thoroughly twice a year (when opening the pool for the season and when winterising it). This is even more important if your pool water is hard. To do this, use a descaling cleaner (see catalogue) and rinse with a water spray.
- Inspect the entire system if an abnormal load is placed on the cover (such as in the event of a fall).
- Inspect the straps annually.
- Do not wash IPE duckboard with a high pressure washer, we recommend washing them regularly with clean water and a non metallic brush.
- Do not run, walk with care, the surface of the gratings can be made slippery by poor maintenance.
- Take care to clean the gratings regularly so that their surfaces do not become slippery.
- If the gratings become slippery, remove them and clean them mechanically.
- Cleaning and maintenance by the user must not be carried out by unsupervised children.

# SERVICING/MAINTENANCE

## MAINTENANCE (ONCE PER YEAR MINIMUM)

- All interventions must be carried out by a professional, who will contact the manufacturer if necessary (contact details on the back page of this document).
- All spare parts must come from the manufacturer or comply with standard NF P90-308.
- Check that the installation is working correctly.
- Inspect the cover thoroughly.
- It is necessary to check at the start of every season and if any accident has occurred (if anything has fallen onto the cover, if hail has struck the cover, if the cover has had to bear any abnormal weight etc...) check that none of the slats has sustained any visible damage that may affect the safety of the cover (cracked slats, holes, deformations, etc...). Make sure that you change the slats or the entire cover if required.
- In summer or in winter, do not place an opaque sheet over the cover: this may damage the slats due to high temperature.
- Check the state of the straps (seams) and in particular the wear on the anti-abrasion sleeve. If the latter is no longer fulfilling its role of protecting the strap against abrasions from the pool rim, then replace it.
- Once a year, check that the electrical connections are sufficiently tight.
- Customer service: contact details on back page of document.

## SERVICING/MAINTENANCE

### WINTERING

- Position the cover in the closed position and keep the water level constant in accordance with the manufacturer's recommendations.



- Winterise the pool according to its geographical location.
- Close the cover in the safety position.
- We recommend installing an Ivernéa winter cover or an Ivernéa Plus protective cover to protect the cover from UV rays and dirt.

# SERVICING/MAINTENANCE

## SPARE PARTS

Online catalogue :



<https://www.my-cfgroup.fr/fr/pièces-detachees>

## TROUBLESHOOTING GUIDE



In-ground pool cover :

<https://view.publitas.com/cfgroup/quick-troubleshooting-guide-unibox-en/>



Wi-key :

<https://view.publitas.com/cfgroup/quick-troubleshooting-guide-wikey/>

## SERVICING/MAINTENANCE

### WARRANTY CONDITION

log on to [www.del-piscine.fr](http://www.del-piscine.fr) to consult all our guarantees.



<https://www.del-piscine.fr/rechercher-une-garantie>

## REPAIR

- Do not hesitate to ask our authorised distributors for advice.
- If the power Câble is damaged, it must be replaced: by the manufacturer, its after-sales service or similarly qualified persons in order to avoid danger.

## SAFETY ADVICE

We recommend that you carefully read the recommendations below.

### WARNING

- **Swimming pools can represent a serious danger for your children. Drowning can happen very quickly.**  
**Children who are close to a swimming pool need to be watched constantly and actively, even if they know how to swim.**
- **The physical presence of an adult is absolutely essential whenever the pool is open.**



- Learn lifesaving skills.
- Memorise the telephone numbers for the emergency services and ensure that they are displayed close to the pool.



## SAFETY ADVICE

- This section is by no means a replacement for common sense or individual responsibility. Its aim is not to replace the vigilance of parents and/or responsible adults, who remain the essential factor in ensuring the protection of young children.
- **Warning:** safety is only guaranteed when the cover is closed, locked and correctly installed in compliance with the manufacturer's instructions.
- The cover must systematically be closed if you are absent from home, even for a very short period.
- Check that no persons and no foreign objects are in the pool before and during opening and closing operations.
- Store the devices and/or tools needed to operate the covers out of the reach of children.
- Operation of the mechanism must only be carried out by a responsible adult.
- With the exception of movable floors, movable terraces and the covering elements provided for this purpose (e.g. gratings), do not climb, walk or jump on a safety cover.
- Take all necessary measures to prevent access to the pool for young children until the cover is repaired or when a malfunction is observed that prevents closing or in case of temporary unavailability of the equipment or the pool.
- Respect the water levels designated by the manufacturer.
- Children must not play with the appliance.
- This appliance may be used by children aged 8 and over, and by persons with reduced physical, sensory or mental capabilities or lack of experience and knowledge if they have received supervision or instructions concerning the safe use of the appliance and understand the hazards involved.

A child can drown in less than 3 minutes, no type of protection can ever replace the watchful eye and vigilance of a responsible adult.

# RECYCLING

## PACKAGING



Dispose of the packaging in line with current rules and regulations.

## END OF LIFECYCLE



- Do not put your scrapped equipment or used batteries in with unsorted household waste.
- You are responsible for disposing of all of your waste, in particular electrical and electronic equipment by taking it to a collection point where recycling and valorisation are carried out.
- Certain products potentially contain substances that are dangerous for the environment, and you need to ensure that these are eliminated or neutralised.
- Make sure that you are aware of all existing recovery and collection systems.



discard the manual in line with the current regulations.



Adresses sur [quefairedemesdechets.fr](http://quefairedemesdechets.fr)



# NOTES



**DEL SAS**  
ZA LA CROIX ROUGE  
35530 BRÉCÉ - FRANCE

☎ +33 (0)9 70 72 5000 / INFO.FR@CF.GROUP

STAMP

A brand by CF group



ORIGINAL INSTRUCTIONS

A-DOTE03501.I1 / 07 2025