

EN

INSTALLATION INSTRUCTIONS

INSTALLATION / UPKEEP / MAINTENANCE / SAFETY ADVICE



**FLEXIBLE RAINWATER
COLLECTION TANK**

CONTENTS

PLEASE READ CAREFULLY AND KEEP FOR FUTURE REFERENCE.

Read this manual carefully to make sure you understand all the information and to ensure safe installation, use and maintenance. We accept no liability for any damage caused by failure to follow the instructions in this manual.

OVERVIEW.....	p. 3
DESCRIPTION.....	p. 4
Components supplied.....	p. 4
Tools required for assembly.....	p. 8
Packaging	p. 8
INFORMATION.....	p. 9
Prerequisites.....	p. 9
Advice on gluing PVC fittings.....	p. 10
INSTALLATION.....	p. 11
Installation of the tank	p. 11
Fitting the collector to the gutter	p. 17
Fitting the drain to the gutter	p. 19
Connecting the tank to the collector	p. 21
Connecting the tank vent	p. 25
Assembly of pump and controller kit.....	p. 30
Connection of the pump/tank, pump section	p. 32
Assembly of the pump, bladder and controller kit	p. 33
Connection of the bladder / tank pump, pump section	p. 35
Water filter kit	p. 36
Connection of the pump / water filter	p. 37
Connection of the tank/pump, tank section	p. 38
USE.....	p. 41
Operation	p. 41
UPKEEP / MAINTENANCE.....	p. 42
Upkeep	p. 42
Maintenance (2 times a year).....	p. 42
Winterising	p. 43
Repair.....	p. 44
SAFETY ADVICE.....	p. 45
GUARANTEE.....	p. 46
RECYCLING	p. 47

OVERVIEW



Thank you for choosing an EDENEA rainwater collection tank. Rainwater collection has both environmental and economic advantages. It is part of a process which combines practical and immediate benefits with a long-term vision for the management of natural resources, promoting a more environmentally-friendly lifestyle.

The tank collects rainwater from your roof via the gutter. This collected water can then be used to water plants and green spaces in the garden, or to clean floors or objects (except for vehicles). It helps to reduce water consumption by your domestic network and redistribute this natural resource directly.

The installation, identification, commissioning and upkeep of rainwater collection systems for on-site use as non-drinking water, as well as the minimum requirements for these systems, are specified in standard NF EN 16941-1.

The maximum capacity of the tank depends on the size purchased. Please refer to the table in the section on components supplied.

DESCRIPTION

DELIVERED ITEMS



FLEXIBLE TANK REFERENCES



Reference	Volume (m3)	Volume (Litres)	Length (m)	Width (m)	Height (m)
Citconfort11	1	1000	2.45	1.48	0.50
Citconfort12	1	1000	2.96	1.35	0.50
Citconfort21	2	2000	4.40	1.48	0.55
Citconfort22	2	2000	2.66	2.05	0.60
Citconfort31	3	3000	5.90	1.48	0.55
Citconfort32	3	3000	2.96	2.50	0.75
Citconfort41	4	4000	6.70	1.48	0.55
Citconfort42	4	4000	3.42	2.66	0.80
Citconfort51	5	5000	8.00	1.48	0.60
Citconfort52	5	5000	3.35	2.96	1.10
Citconfort61	6	6000	4.50	2.66	0.80
Citconfort62	6	6000	3.95	2.96	1.10
Citconfort81	8	8000	4.80	2.96	1.00
Citconfort82	8	8000	5.90	2.66	0.80

DESCRIPTION

FLEXIBLE TANK REFERENCES CONT.

Reference	Volume (m3)	Volume (Litres)	Length (m)	Width (m)	Height (m)
Citconfort101	10	10000	5.50	2.96	0.90
Citconfort102	10	10000	4.44	3.70	0.95
Citconfort151	15	15000	4.80	4.44	1.30
Citconfort152	15	15000	5.92	3.70	1.15
Citconfort153	15	15000	9.50	2.66	0.80
Citconfort201	20	20000	6.10	4.44	1.30
Citconfort202	20	20000	8.84	3.50	0.90
Citconfort203	20	20000	12.50	2.66	0.80
Citconfort251	25	25000	7.00	4.44	1.30
Citconfort252	25	25000	12.50	2.96	1.05
Citconfort253	25	25000	15.20	2.66	0.80
Citconfort301	30	30000	6.25	5.92	1.20
Citconfort302	30	30000	8.20	4.45	1.30
Citconfort303	30	30000	14.80	2.96	1.05



ACCESSORIES SUPPLIED WITH THE TANK

	12-metre rolls of Teflon tape	X2
	BLUETITE THF-free glue 250ML Special soft PVC	X1



	Ø50 Valve	X2
	Elbow for vent	X1

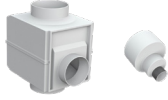

DESCRIPTION

COLLECTORS





	Collector with filter for Ø 100 round gutter	X1
or		
	Collector with filter for Ø 80 round gutter	X1

TANK / COLLECTOR CONNECTION KIT

	90° elbow, Ø50 female/female, for bonding	X1
	Ø50 fluted PVC end cap for gluing	X2

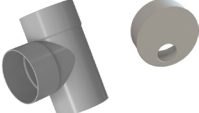
	Corrugated hose, Ø50 UV-resistant	5m
	hose clamp	X2

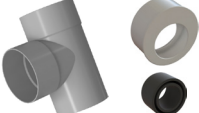
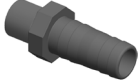

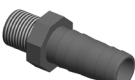
OVERFLOW KIT

	Ø100 PVC MFF tee fitting + Ø100 plug	X1		Corrugated hose, Ø32 UV-resistant	10m
or				hose clamp	X2
	PVC MFF Ø80 tee fitting + Ø80 plug + reducer	X1		Ø32 fluted PVC socket for gluing	X1
	Reduced 90° elbow 32/25	X1			
	Ø32 ribbed PVC screw-on socket	X1			

DESCRIPTION



TANK/PUMP CONNECTION KIT

	Ø50 PVC socket for gluing	X1
	Ø50 Ø32 ribbed PVC socket for gluing	X1
	Ø50 non-return valve for gluing	X1



	Corrugated hose, Ø32 UV-resistant	5m
	Clamping collar	X2
	12-metre rolls of Teflon tape	X1

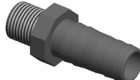

PUMP KIT WITH CONTROLLER

	Jetcom 3/4 C V mono booster with pump controller	X1
--	--	----

	MF brass elbow (Male Female)	X1
	Tap connector 26/34	X1
	Screw-in socket Ø32 - fluted Ø30-32	X1

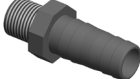

PUMP KIT WITH CONTROLLER AND BLADDER

	Jetcom 3/4 C V mono pressure booster with 20-litre bladder tank	X1
	Screw-in brass equal nipple	X1

	MF brass elbow (Male Female)	X1
	Tap connector 26/34	X1
	Ø32 Screw-in socket - fluted Ø30-32	X1

WATER FILTER KIT



	NW25 3/4" water filter	X1
---	------------------------	----

	MF 3/4" brass valve	X2
	Clamping collar	X2

DESCRIPTION

TOOLS REQUIRED FOR ASSEMBLY

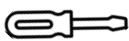

	Measuring tape
	Level

	Saw
	Flat screwdriver





PACKAGING



Pallets: 1.20 x 0.80 x 1.00 m - variable Kg

INFORMATION

PREREQUISITES

	<p>Make sure there is enough space to fully install the tank and its accessories.</p> <p>The floor must be able to support the weight of the full flexible tank without settling. Reminder (1000 litres = 1000Kg = 1 tonne)</p> <p>Ideally, the tank should be placed on a bed of sand a few centimetres deep with a ground cover (geotextile or PVC fabric).</p> <p>The tank can be installed in your garden, your crawl space or under your terrace, close to a gutter on your house to be supplied.</p>
 EAU NON POTABLE	<p>Rainwater is not drinkable: Even filtered, it can only be used for purposes that do not require drinking water.</p>
	<p>The flexible pipe must not be taut, but must be able to rest in front of the tank.</p> <p>It is incumbent on the user to ensure that their entire system complies with current regulations.</p>
	<p>Remember to wear safety equipment.</p>

! WE RECOMMEND READING ALL THE INSTALLATION STEPS BEFORE INSTALLATION TO AVOID UNNECESSARY HANDLING.

INFORMATION

ADVICE ON GLUING PVC FITTINGS



1. Clean the surfaces of the parts to be glued with a cloth and PVC stripper.

Example:



2. Apply a thin layer of adhesive evenly to all surfaces, as shown below.

Example:

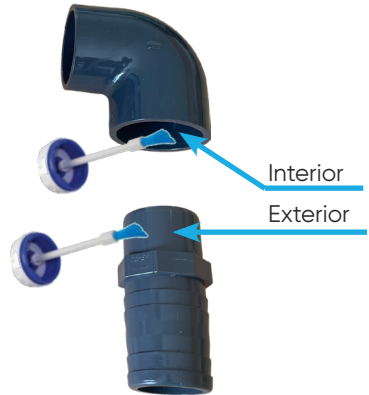

3. Clean up any excess glue as soon as you have connected the PVC fittings.

INSTALLATION

INSTALLING THE TANK





	Tank	X1
	Teflon tape	X1

	Ø50 Valve	X2
	Elbow for vent	X1

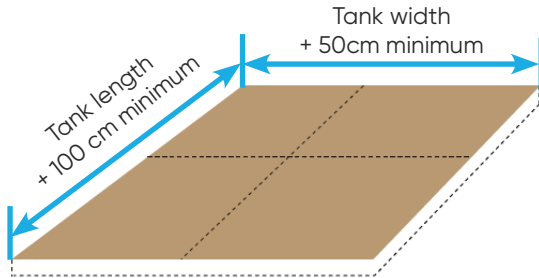
STEP 1 - PREPARE THE FLOOR.



	Measuring tape
	Level

- Make sure the support on which the water tank will be installed is strong enough.
- Choose a suitable location, such as a garden, crawl space or under the terrace, close* to a gutter that collects rainwater.
 - * Pay attention to the distance between the tank and the gutter, as corrugated pipes can be up to 10 metres long.
- The surface must be at least 25cm larger on each side of the tank width and 50cm larger on each side of the tank length.

INSTALLATION

- Create a base slab in the defined area to stabilise the tank.



The sand must always be retained on all sides, compacted and thick enough to ensure that there are no contending elements in contact with the tank.

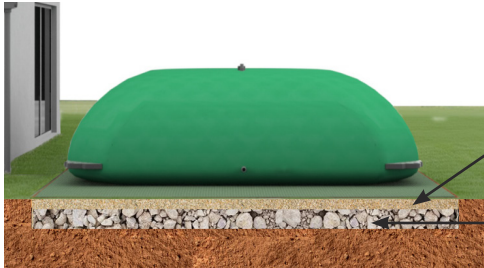

Sand retained by soil
(5 to 15cm)

Compacted gravel
(10 to 15cm)



Concrete formwork

Sand retained by concrete
(5 to 15cm)

Compacted gravel
(10 to 15cm)



Sand not retained

INSTALLATION

- The surface on which the tank is to be placed must be flat, horizontal, stable and free of any roughness that could perforate, cut or deform it, and must be able to support the weight of the water tank.

Type of non-compliant installation:

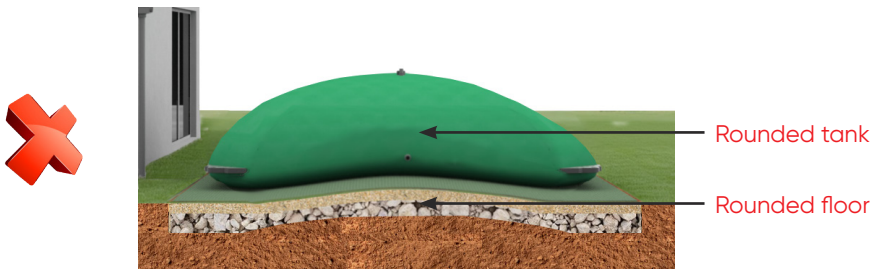
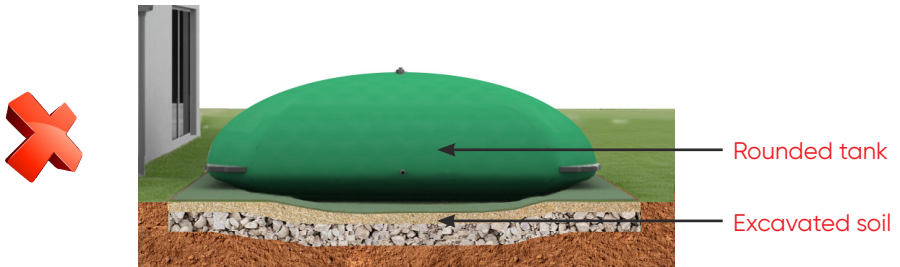
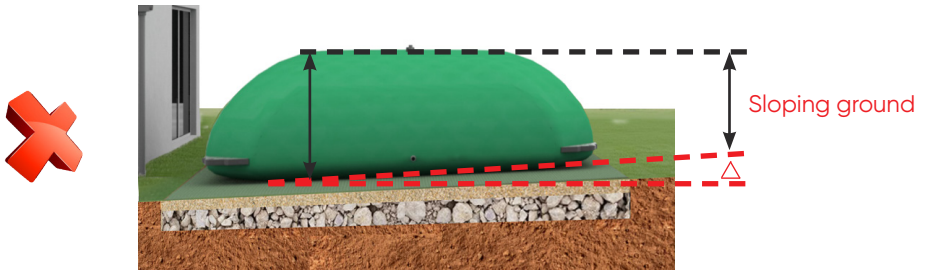

A system that does not comply with the above recommendations risks:



- **Deformation of the tank.**
- **Premature wear and tear.**
- **Overpressure or loss of capacity.**
- **Loss of warranty**

INSTALLATION

STEP 2 (OPTIONAL) - LAY A GEOTEXTILE OR GROUND SHEET.

Protection not supplied

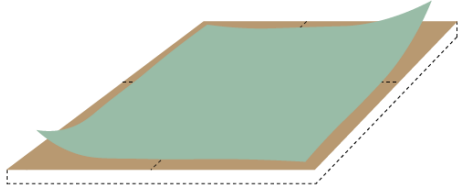

STEP 3 - LAY OUT THE TANK.

1. Install the tank with the vent and trap cap outlets to the sky.

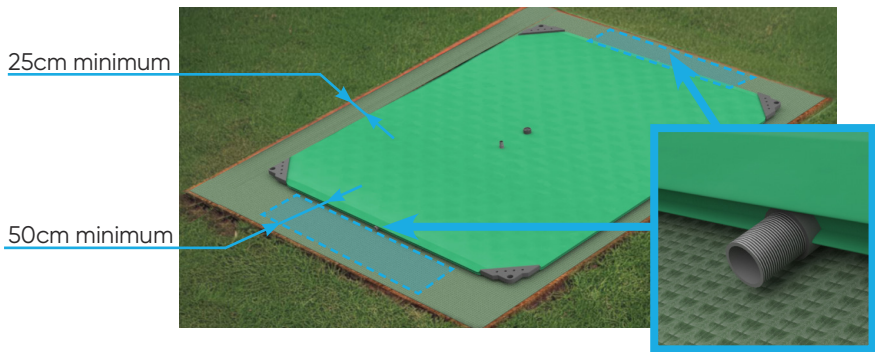
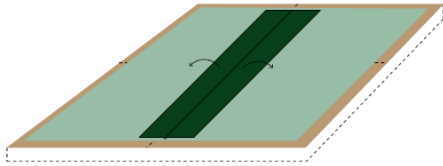

2. Adjust the position of the tank.
3. Leave a space in front of the tank connections.



Best practice :

- Lift the tank from two corners to move it.
- do not pull from just one corner
- create a cushion of air underneath it, to move it.
- Don't leave any folds.

INSTALLATION

STEP 5 - CONNECT THE VALVES TO THE TANK.

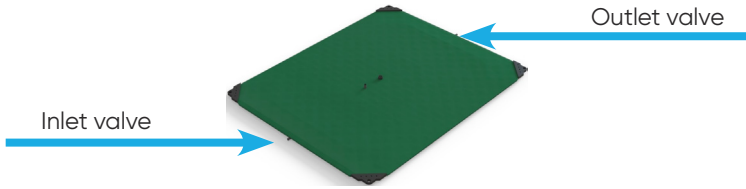

1. Ensure the bulkhead nut is properly tightened.

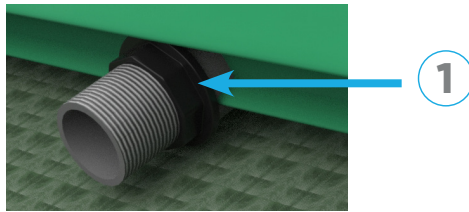

2. Add a layer of Teflon around the wall bushing thread.

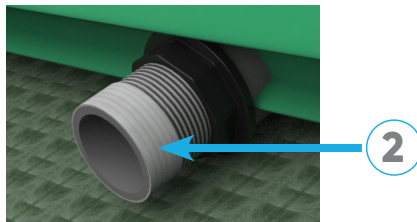

3. Screw the valves onto the tank wall bushings.

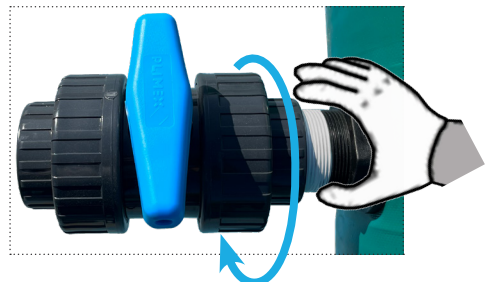
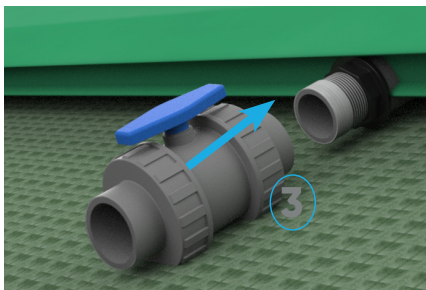

Hold the nut so as not to unscrew the wall bushing.

INSTALLATION

STEP 5 - CONNECT THE TANK VENT.

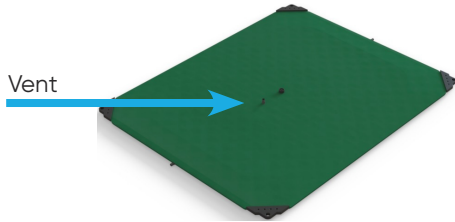

1. Add a layer of Teflon tape around the vent thread.

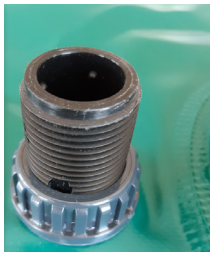



2. Screw the Ø32 90° elbow onto the vent.



INSTALLATION

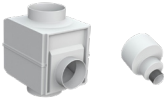

MOUNTING THE COLLECTOR TO THE GUTTER

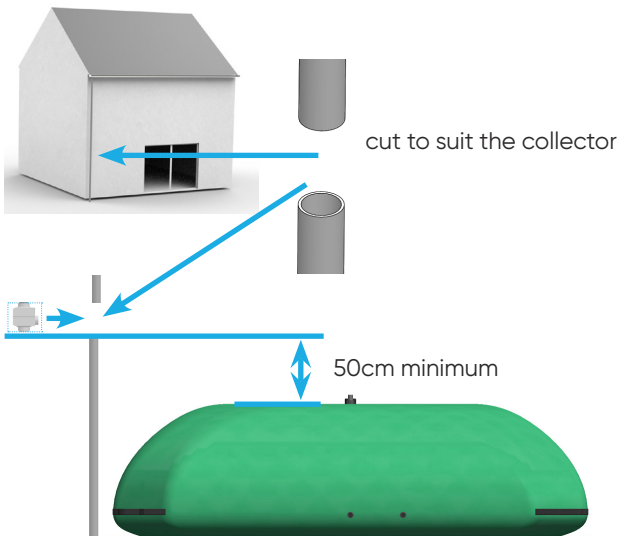

	Collector with filter for Ø 100 round gutter	X1
or		
	Collector with filter for Ø 80 round gutter	X1

STEP 1 - SAW YOUR RAINWATER INLET GUTTER.



	Measuring tape
	Saw

Cut the gutter to match the size of the collector, so that the bottom of the collector is always above the top of the fully-filled tank.

INSTALLATION

STEP 2 - INSTALL YOUR COLLECTOR.

- If your gutters have a diameter of 80mm, you will need to use the adapters supplied.

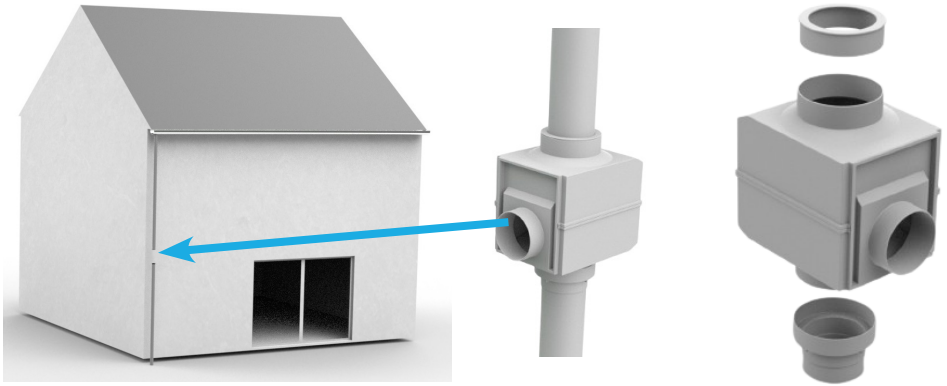

- For Ø80 and Ø100 collectors, a front adaptor must be fitted.

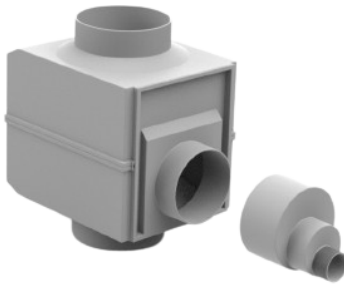

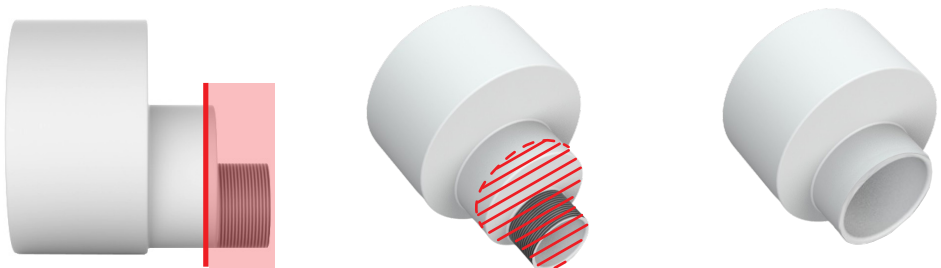

Cut the adaptor as shown in the diagrams below.



INSTALLATION

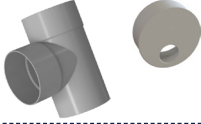
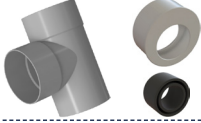

FITTING THE TANK OVERFLOW

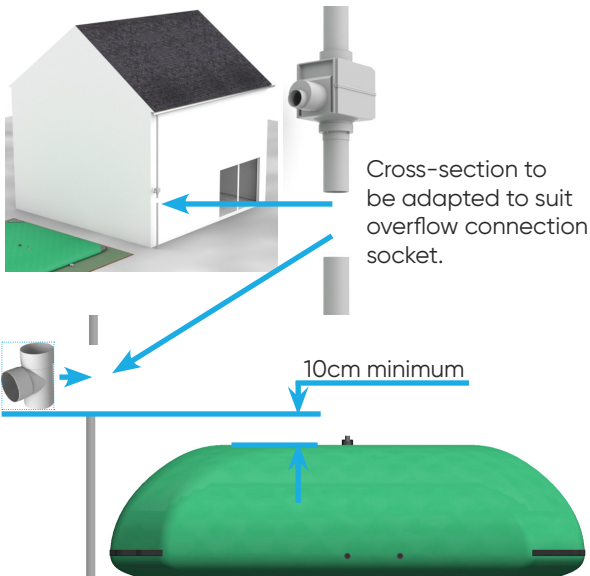

	Ø100 PVC MFF Tee fitting + Ø100 plug	X1
	or PVC MFF Ø80 tee fitting + Ø80 plug + reducer	X1
	Reduced 90° elbow 32/25	X1

STEP 1 - SAW YOUR RAINWATER INLET GUTTER.



	Measuring tape
	Saw

Cut the gutter to match the diameter of the overflow connection pipe, so that the bottom of the tee fitting is always above the **top of the full tank**.

INSTALLATION

STEP 2 - INSTALL THE OVERFLOW CONNECTION TEE FITTING.

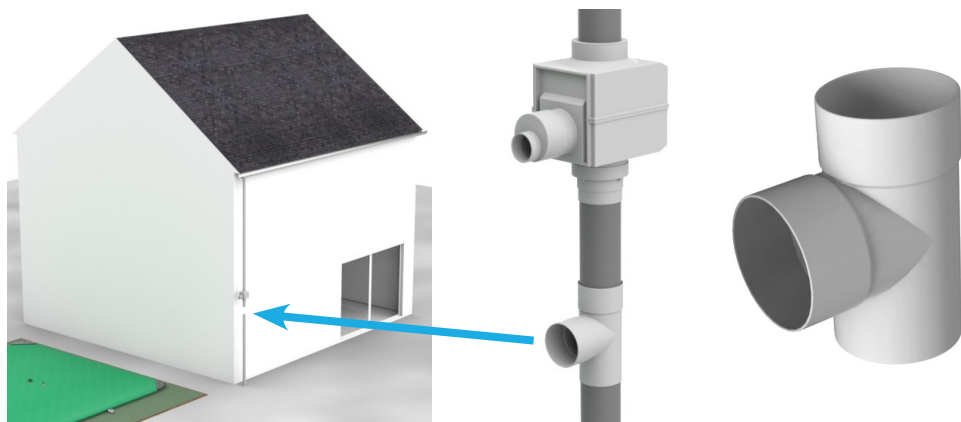

STEP 3 - GLUE THE CAP AND ACCESSORIES.

With a Ø80 tee fitting:

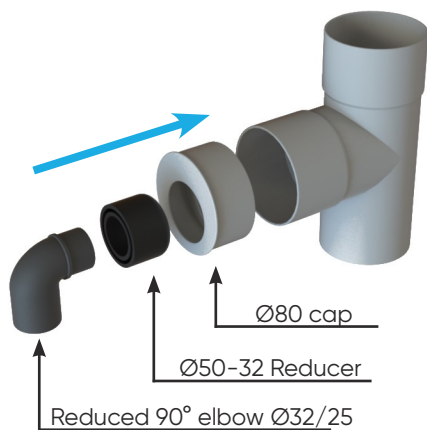

With a Ø100 tee fitting:

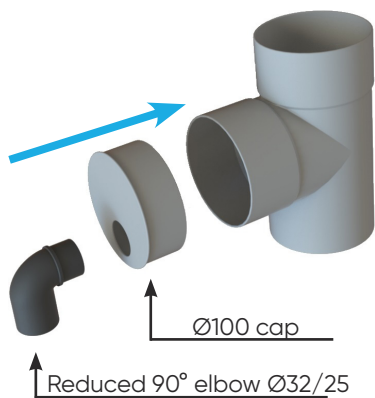

Elements for gluing.
See page 10





INSTALLATION

CONNECTION OF THE TANK TO THE COLLECTOR.



	Tank	X1
	90° elbow, Ø50 female/female, for gluing	X1
	Ø50 fluted PVC socket for gluing	X2

	Corrugated hose, Ø50 UV-resistant	X1
	hose clamp	X2



Best practice :

- See page 10 for instructions on how to glue the sockets.

STEP 1 - GLUE THE RIBBED PVC SOCKET TO THE VALVE.

- Apply glue to the PVC socket and the valve, then insert it into the tank valve (valve open) as far as it will go.

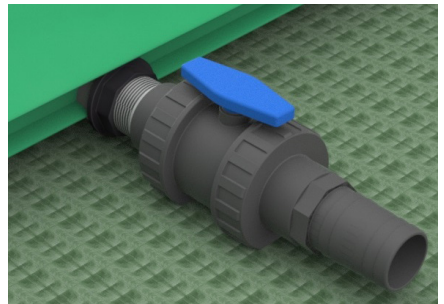
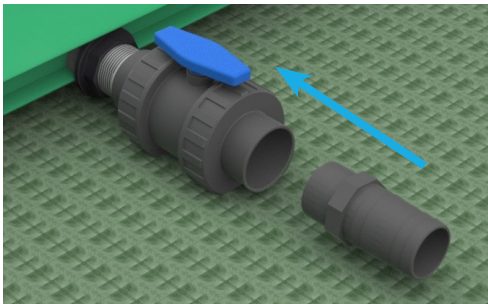

INSTALLATION

STEP 2 - CONNECT THE CORRUGATED HOSE.

1. Insert the clamp on the corrugated tube.
2. Insert the corrugated tube as far as it will go into the grooved PVC socket.
3. Tighten the clamp.

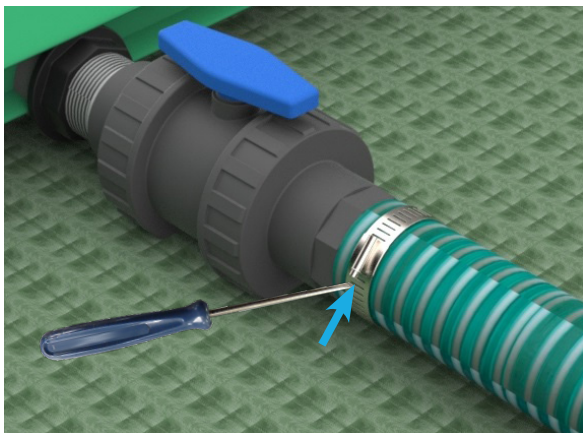
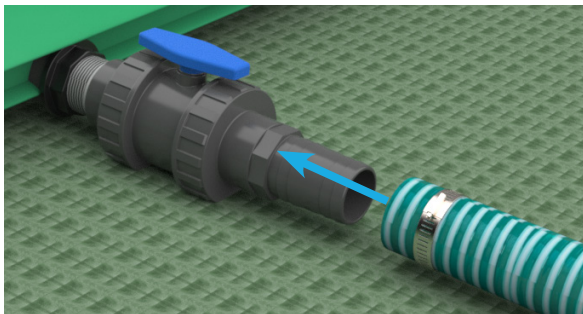
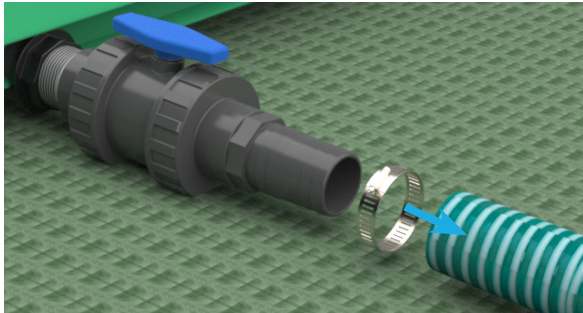

Flat
screwdriver

INSTALLATION

STEP 3 - GLUE THE 90° ELBOW TO THE COLLECTOR.



STEP 4 - GLUE A SMOOTH Ø50 CORRUGATED PVC SOCKET INTO THE 90° ELBOW.

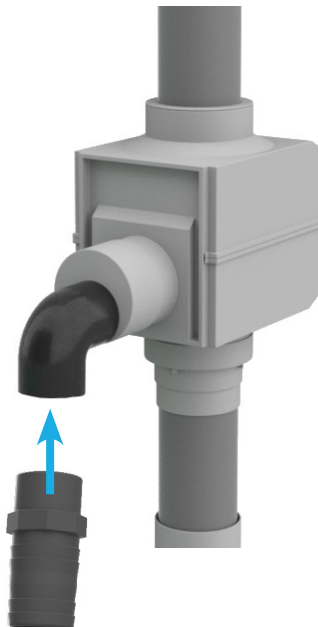

INSTALLATION

STEP 5 - CONNECT THE CORRUGATED HOSE.

1. Insert the clamp on the corrugated tube.
2. Insert the corrugated tube as far as it will go into the grooved PVC end cap.
3. Tighten the clamp.

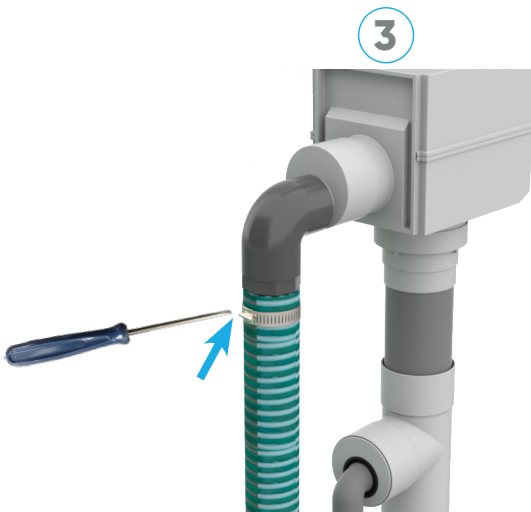
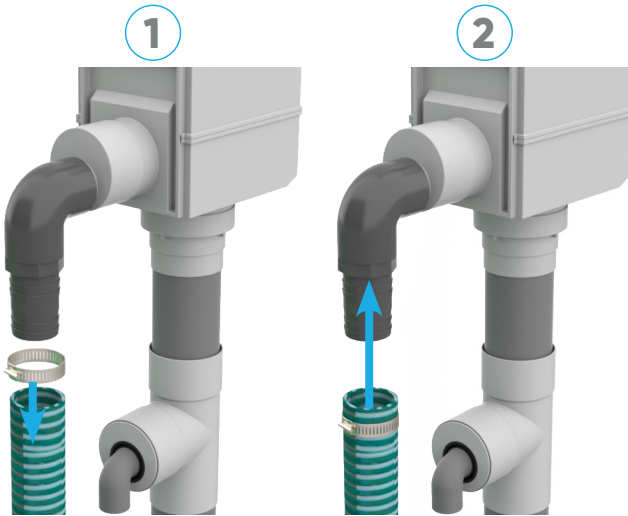



Flat
screwdriver

INSTALLATION

CONNECTING THE TANK VENT

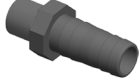

	12-metre roll of Teflon tape	X1
	Ø32 ribbed PVC screw-on socket	X1

	Corrugated hose, Ø32 UV-resistant	X1
	hose clamp	X2
	Ø32 smooth corrugated PVC socket	X1

STEP 1 - ADD A LAYER OF TEFLON TAPE AROUND THE THREADS OF THE THREADED PVC SOCKET.

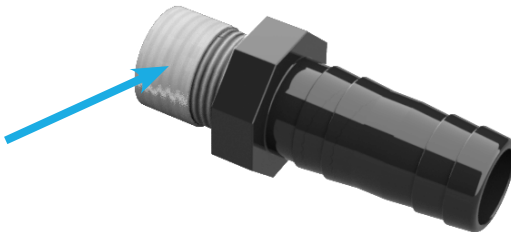

STEP 2 - SCREW THE SOCKET INTO THE Ø32 90° ELBOW.



INSTALLATION

STEP 3 - CONNECT THE CORRUGATED HOSE.

1. Insert the clamp on the corrugated tube.
2. Insert the corrugated tube as far as it will go into the ribbed PVC socket.
3. Tighten the clamp.

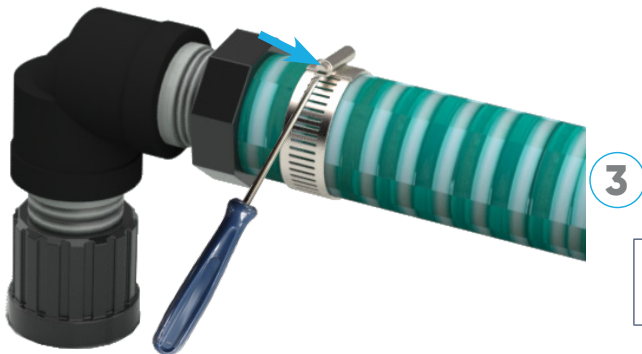
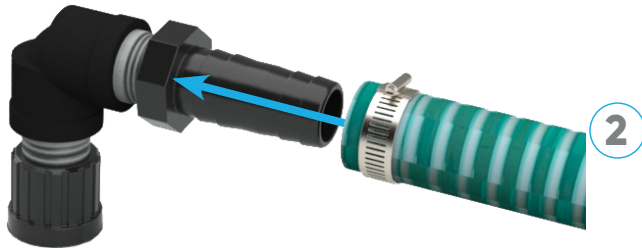
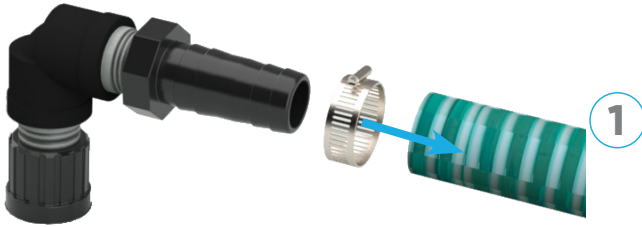

Flat
screwdriver

INSTALLATION

STEP 4 - GLUE A SMOOTH Ø32 RIBBED PVC SOCKET INTO THE 90° ELBOW.



Elements for gluing.
See page 10

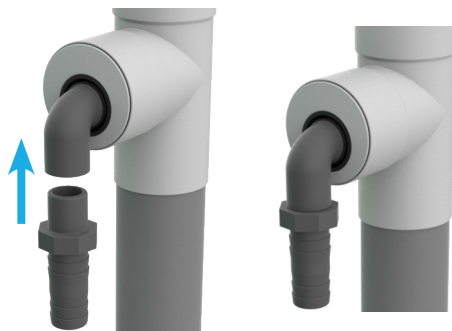

STEP 5 - CONNECT THE CORRUGATED HOSE.

1. Insert the clamp on the corrugated tube.
2. Insert the corrugated tube as far as it will go into the ribbed PVC socket.
3. Tighten the clamp.

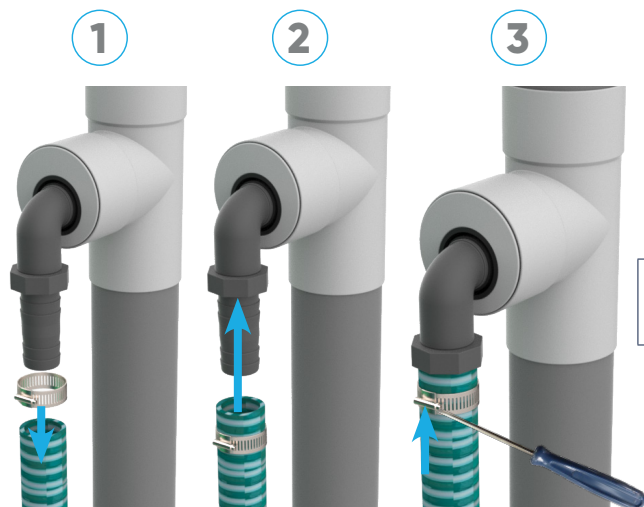

Flat
screwdriver

INSTALLATION

VIEW OF THE TANK INSTALLED OUTDOORS

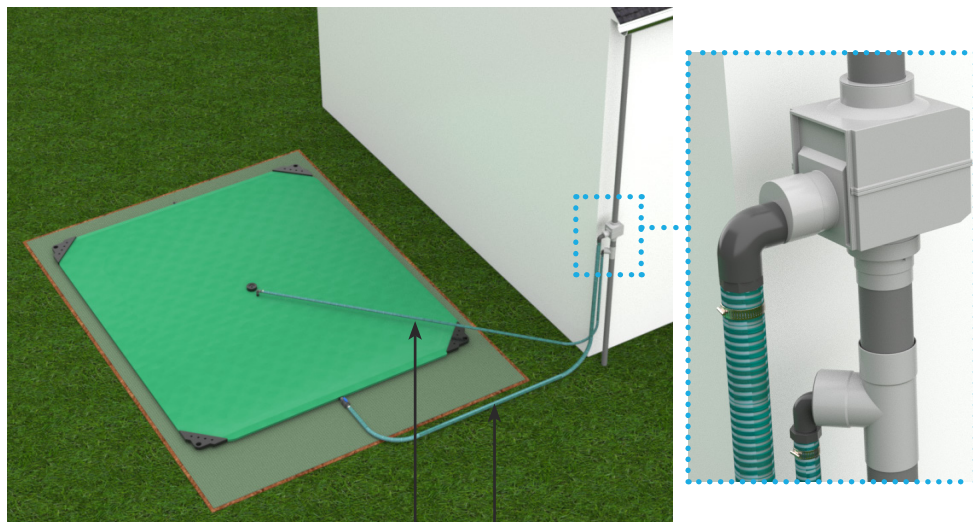

10-metre Ø32 corrugated hose

5-metre Ø50 corrugated hose

VIEW OF THE TANK INSTALLED IN THE CRAWL SPACE

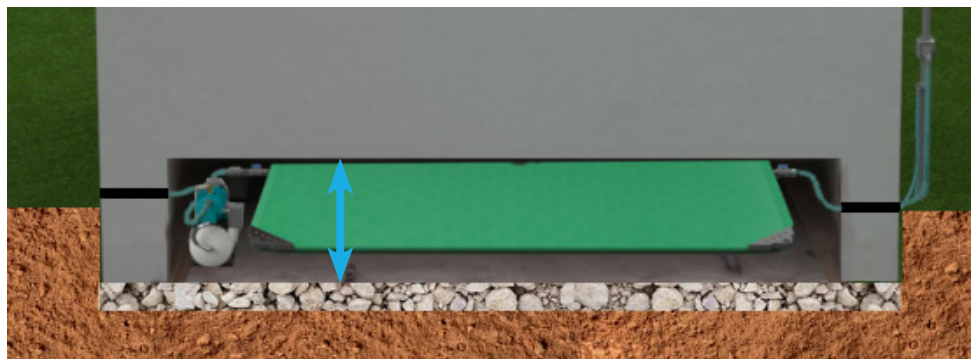

The height of the crawl space must be at least 1 metre.

CAUTION: for installation in a crawl space, check that the connections are watertight.

INSTALLATION

Pumping systems



Booster pump with pressure switch for watering or cleaning.



Pressure booster with pressure switch and bladder for connection to a high-pressure cleaner.





The pumps are connected electrically via a 220V single-phase socket. (see pump manual supplied).

INSTALLATION

ASSEMBLY OF PUMP AND CONTROLLER KIT

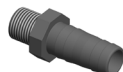

	Jetcom 3/4 C V mono booster with pump controller	X1
--	--	----

	MF brass elbow (Male Female)	X1
	26/34 Valve body	X1
	Teflon tape	X1
	Screw-in socket Ø32 - ribbed Ø30-32	X1

The pump kit should be installed in a place protected from the weather, on a stable support and close to an electrical socket that complies with the current standard.

PUMP CONTROLLER / MF BRASS ELBOW

1. Apply Teflon to the inlet thread of the pump controller.
2. Screw the female end of the brass elbow onto the pump inlet thread.



INSTALLATION

MF BRASS ELBOW / TAP CONNECTOR

1. Apply Teflon to the thread of the MF brass elbow.
2. Screw the tap connector onto the thread of the MF brass elbow.



MF brass elbow inlet thread

PUMP CONTROLLER / RIBBED FITTING

1. Apply Teflon to the thread of the ribbed fitting.
2. Screw the ribbed fitting onto the pump inlet.

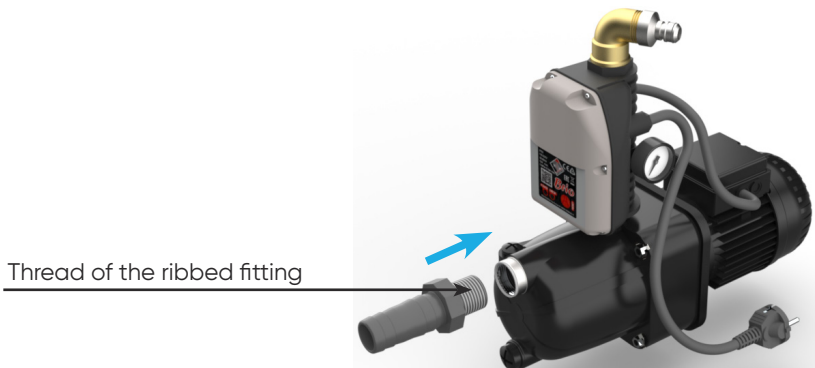



Thread of the ribbed fitting

INSTALLATION

PUMP / TANK CONNECTION, PUMP SECTION



	Jetcom 3/4 C V mono booster with pump controller	X1		Corrugated hose, Ø32 UV-resistant	X1
				hose clamp	X1
				Teflon tape	X1

1. Insert the clamp on the corrugated tube.
2. Insert the corrugated tube as far as it will go into the ribbed PVC socket.
3. Tighten the clamp.



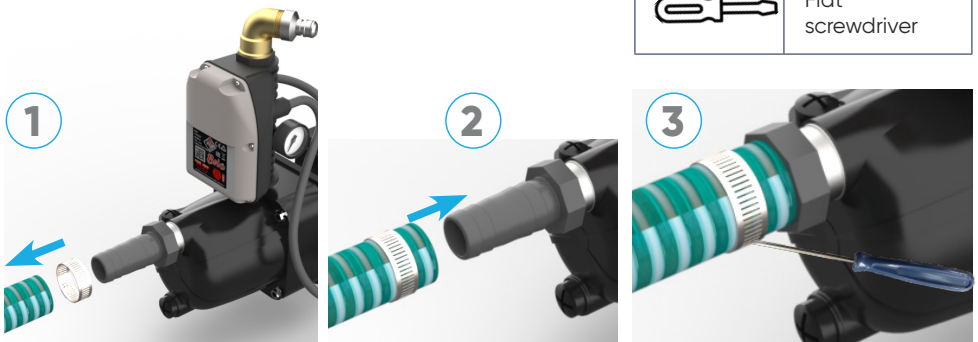

Flat
screwdriver





INSTALLATION

ASSEMBLY OF PUMP, BLADDER AND CONTROLLER KIT

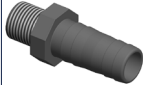

	Jetcom 3/4 C V mono pressure booster with 20-litre bladder tank	X1
	Threaded brass equal nipple	X1

	MF brass elbow (Male Female)	X1
	Tap connector 26/34	X1
	Teflon tape	X1
	Screw-in socket Ø32 - ribbed Ø30-32	X1

The pump kit should be installed in a place protected from the weather, on a stable support and close to an electrical socket that complies with the current standard.

EQUAL BRASS NIPPLE / MF BRASS ELBOW / TAP CONNECTOR

1. Apply Teflon to the 2 threads of the brass nipple.
2. Screw the brass elbow onto the equal brass nipple.
3. Screw the tap connector onto the MF brass elbow.

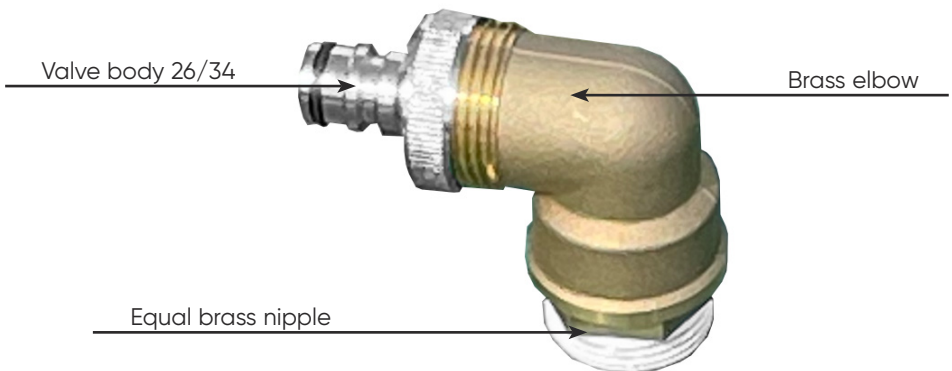

INSTALLATION

BOOSTER / MF BRASS ELBOW

Screw the brass elbow assembly onto the top outlet of the booster.

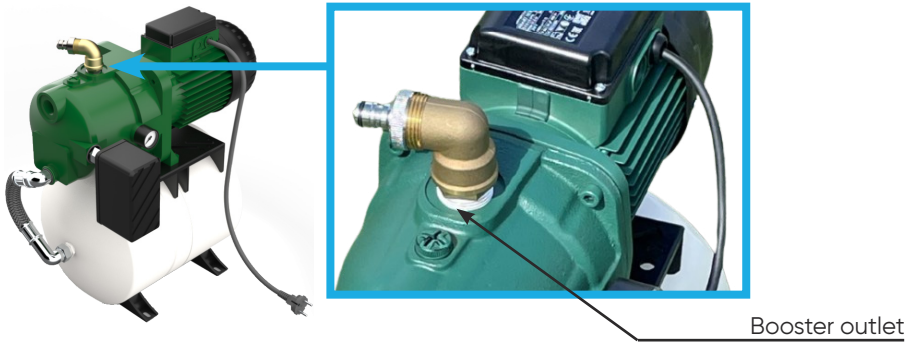

PUMP CONTROLLER / RIBBED SOCKET

1. Apply Teflon to the thread of the ribbed socket.
2. Screw the hose barb onto the pump inlet.

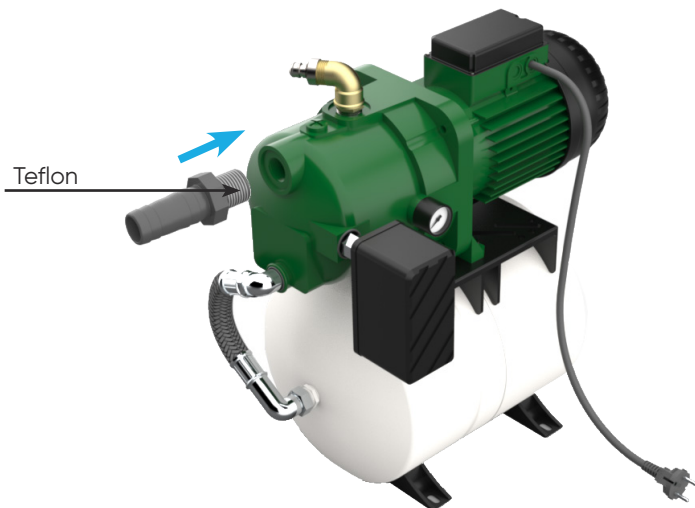

INSTALLATION

BLADDER / TANK PUMP CONNECTION, PUMP SECTION



	Jetcom 3/4 C V mono booster with pump controller	X1		Corrugated hose, Ø32 UV-resistant	X1
				Clamping collar	X1
				Teflon tape	X1

CONNECT THE CORRUGATED HOSE

1. Insert the clamp on the corrugated tube.
2. Insert the corrugated tube as far as it will go into the ribbed PVC socket.
3. Tighten the clamp.

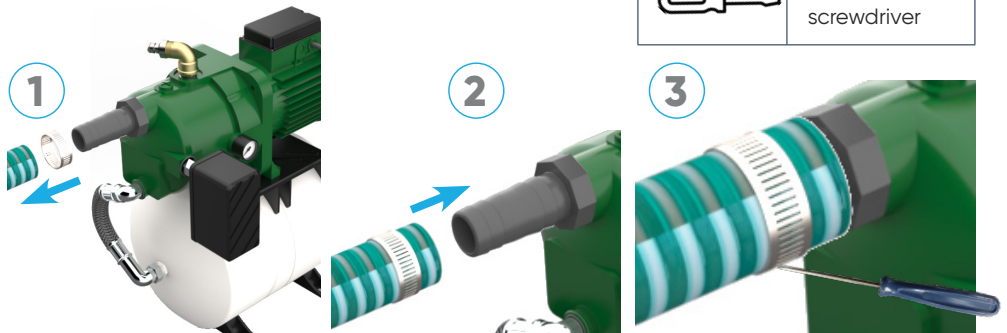

	Flat screwdriver
---	---------------------

INSTALLATION

WATER FILTER KIT



	NW25 3/4" water filter	X1
---	---------------------------	----

	MF 3/4" brass valve	X2
	Teflon tape	X1

The water filter is added when using a high-pressure cleaner. It filters out any small particles that may be in the water.

CONNECT THE FILTER

1. Apply Teflon to the valve threads.
2. Screw the brass valves on either side of the filter.

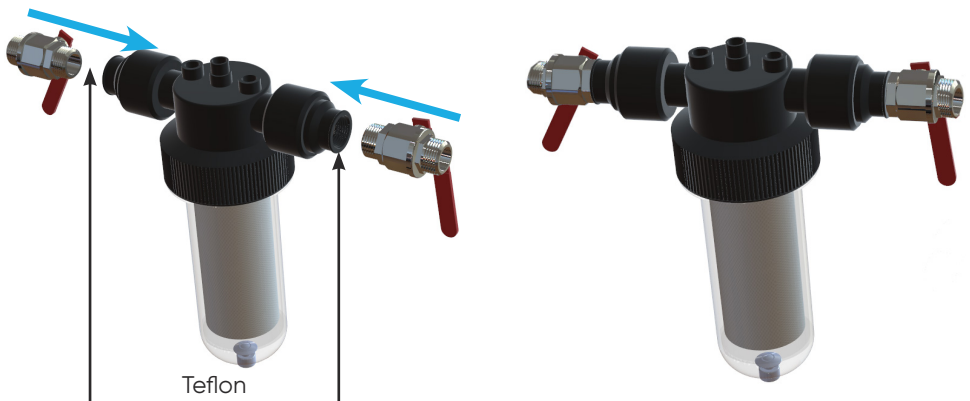



INSTALLATION

CONNECTION OF THE PUMP / WATER FILTER



	NW25 3/4" water filter	X1
--	------------------------	----

	Connecting hose (not supplied)	X1
	Tap connector 26/34 (not supplied)	X2

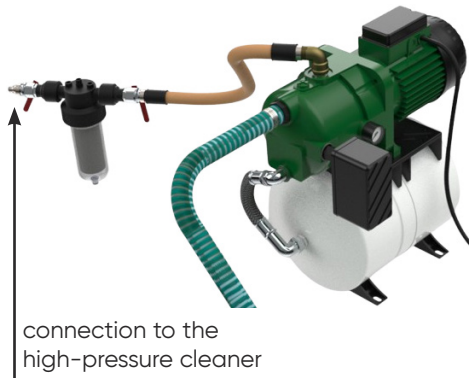
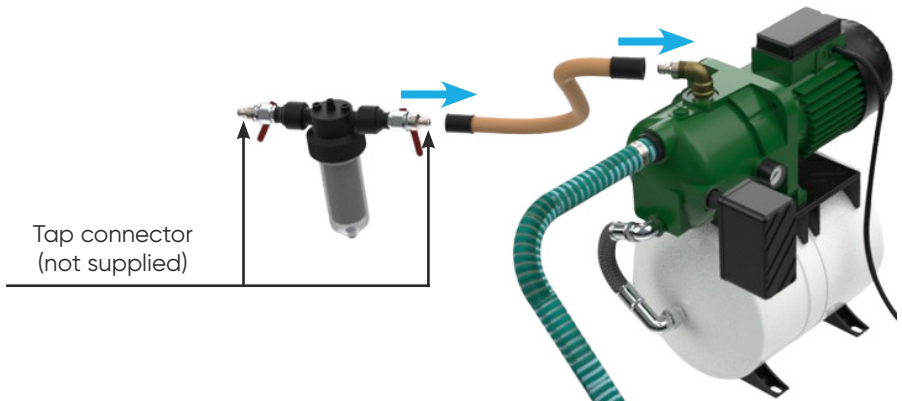

CONNECT THE PUMP TO THE WATER FILTER



INSTALLATION

TANK/PUMP CONNECTION, TANK SECTION

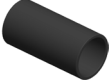
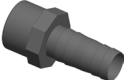
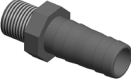

	Ø50 PVC glue-on socket	X1
	Ø50 Ø32 ribbed PVC socket for gluing	X1
	Ø32 ribbed PVC screw-on socket	X1
	Anti-return valve Ø50	X1

	Corrugated hose, Ø32 UV-resistant	X1
	Clamping collar	X2
	BLUETITE glue	X1
	Teflon tape	X1



Best practice :

- See page 4 for instructions on how to glue the end caps.

STEP 1 - GLUE THE Ø50 TUBE SOCKET INTO THE TANK'S 2ND VALVE.

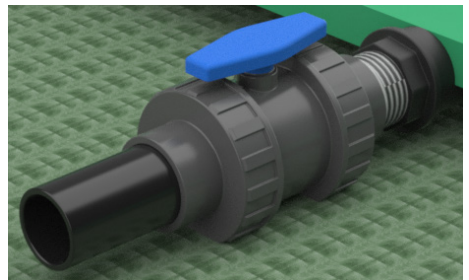
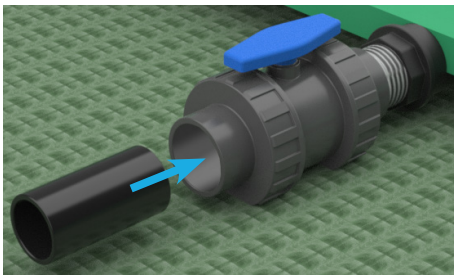

INSTALLATION

STEP 2 - GLUE THE NON-RETURN VALVE TO THE Ø50 PIPE SOCKET.

! The non-return valve has a mounting direction, so take care when gluing it in place.

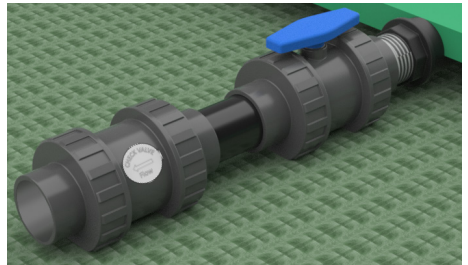
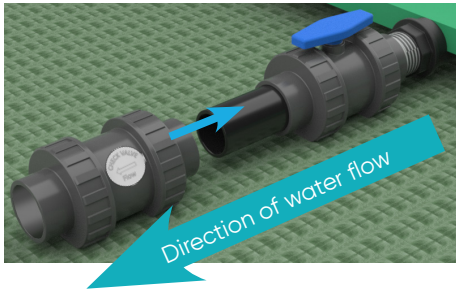

STEP 3 - GLUE THE Ø50 RIBBED Ø32 PVC SOCKET INTO THE NON-RETURN VALVE.

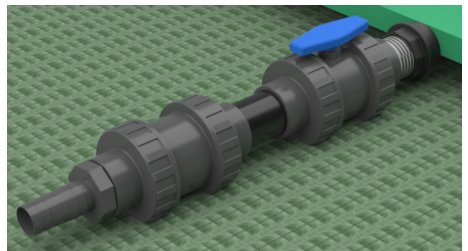
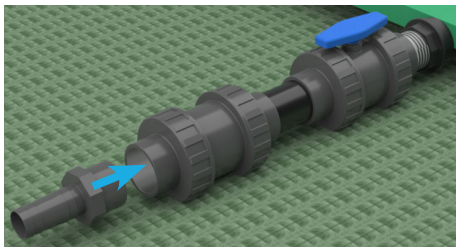

INSTALLATION

STEP 4 - CONNECT THE CORRUGATED HOSE

1. Insert the clamp on the corrugated tube.
2. Insert the corrugated tube as far as it will go into the ribbed PVC socket.
3. Tighten the clamp.

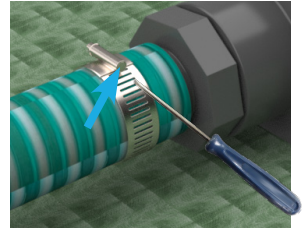
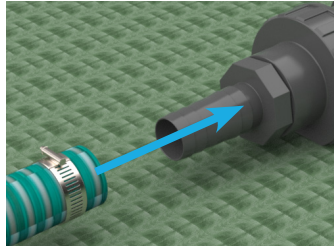
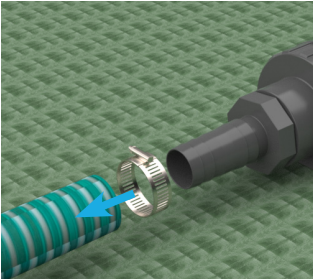

USE

OPERATION

It is incumbent on the user to ensure that the entire system complies with current regulations.

FILLING

- Filling is done via the collector, which filters and diverts the rainwater to the cistern.
- The connection to the tank must be made using flexible pipework to withstand variations in tank level.
- Once the tank is full, the water will drain into the tank's overflow. Make sure you never block the overflow.

DISTRIBUTION



The pumps are connected electrically via a 220V single-phase socket. (see details in the pump technical manual).

The stored rainwater is distributed via the pump:

1. Connect a garden hose to the tap connector.
2. Connect the pump to a 220 V single-phase electrical socket (power supply in compliance with the current standard).

UPKEEP / MAINTENANCE

Any work on the electrical parts must only be carried out by a qualified person and must comply with the manufacturer's instructions and the standards and regulations in force.



When carrying out work, technicians must wear their PPE (Personal Protective Equipment): gloves, goggles, mats, etc.

We recommend powering the system down before carrying out any work.

UPKEEP

- The tank must be cleaned once a year.
- In winter, it is essential to insulate the inlet/outlet pipes and the valve or optional kits.
- Regularly check the tightness of the various components.
- If the tank is to be stored for a long time, fold it and make sure it is completely dry. Protect the various components (valve, vent, etc.).
- Do not apply anti-freeze to the storage tank.

You are also required to keep an up-to-date sanitary maintenance log for your equipment. This document must contain the following information:

- Name and address of the servicing company if you do not carry out the servicing yourself
- Detailed plan of your rainwater collection equipment
- Commissioning form
- Dates of checks and maintenance operations carried out
- Monthly reading of the indexes of the systems used to measure the volume of rainwater used inside your home connected to the wastewater collection system.
- If your home is rented out, you must inform your tenant about the operation of your rainwater collection equipment.
- If you are selling your home, you must inform the buyer by any means of the existence of this equipment.



You must not apply antifreeze to the storage tank.

UPKEEP / MAINTENANCE

EACH TIME YOU USE IT

- Carry out a visual check of the components.

EVERY 6 MONTHS

- Every 6 months you must check that your equipment is clean and that the non-drinking water identification plate is affixed. You should also check that there is no connection between the network intended for human consumption and the rainwater distribution network.

EVERY YEAR

- You must clean the filters and drain, clean and disinfect the storage tank every year (yourself or a company of your choice). You should also check (or have checked) the valves and taps.

MAINTENANCE (TWICE A YEAR)

- Check that the system is working properly.
- Check tightening and electrical connections and that the overflow is not blocked.
- Technical support: contact details on the back of the document.

WINTERISING

- In winter, it is essential to insulate the inlet/outlet pipes and the valve or optional kits

UPKEEP / MAINTENANCE

REPAIR

Despite the sturdiness of the fabric, should you damage it, a repair kit is supplied with the tank.

Before repairing the tank, carefully clean the damaged area, then sandpaper both sides to be glued and proceed as follows:

- Cut the PVC piece supplied with the kit (larger than the surface to be repaired, rounded corners).
- Apply the adhesive to the PVC part
- Apply the PVC patch to the damaged area, removing any air bubbles.
- Keep the two parts in contact
- Leave to act for 24 hours to ensure perfect adhesion.

SAFETY ADVICE

- This appliance may be used by children aged 8 and over, and by persons with reduced physical, sensory or mental capabilities or lack of experience and knowledge if they have received supervision or instructions concerning the safe use of the appliance and understand the hazards involved.
- Children must not play with the appliance.
- Recovered water is non-drinkable and must not be consumed. In the event of someone drinking it, contact the Poison Control Centre.

 **18** (in France) or **112**

FIRE BRIGADE

 **15**

AMBULANCE
SERVICE

(write the number corresponding to your region)



POISON CONTROL
CENTRE

GUARANTEE

- To validate the guarantee and ensure correct operation, the system must be installed in accordance with the instructions in this document.
- The flexible tank is guaranteed for five years from the date of delivery. The rest of the components and electrical equipment are guaranteed for 2 years.
- Work carried out under the terms of the guarantee shall not have the effect of extending the duration of the guarantee. However, any period of immobilisation of a component sent for repair for more than seven days will extend the remaining guarantee period by the same amount.
- To benefit from this guarantee, a request for guarantee must first be submitted to EDENEA's after-sales service , whose agreement is essential for any replacement or return for repair.
- In addition, presentation of the sales invoice will be strictly required when the guarantee is invoked.
- This guarantee is subject to strict compliance with the assembly and/or maintenance instructions. The guarantee will not apply in the event of non-compliance with these conditions.
- Under this guarantee, EDENEA's only obligation will be, at EDENEA's discretion, the free replacement or repair of the product or component recognised as defective by EDENEA's services. All other costs will be borne by the purchaser.
- Defects and damage caused by normal wear and tear, defects resulting from incorrect assembly and/or use, and product modifications carried out without EDENEA's consent, as well as holes, tears, snags, discolouration, creases and stains, are excluded from the guarantee. The costs associated with removal, re-installation, labour, filling, draining, transport and any other products used are not covered by the warranty.

RECYCLING

PACKAGING



Dispose of the packaging in accordance with rules and regulations in force.

END OF LIFE



- Do not dispose of your discarded appliances or used batteries with unsorted household waste.
- You are responsible for handing over all your waste, particularly electrical and electronic equipment, to a dedicated collection point for recycling and recovery.
- Some products could contain substances which are dangerous for the environment. These will be eliminated or neutralised.
- Find out about existing collection and return systems.
www.quefairedemesdechets.fr



When replacing the product, dispose of the manual in accordance with rules and regulations in force.



Adresses sur quefairedemesdechets.fr

Manufactured by
SAS AQUALUX
ZAC DE LA MASSANE
287 AVENUE DE LA MASSANE
13210 ST RÉMY DE PROVENCE - FRANCE

STAMP

Sold by



EDENEA.COM/SERVICE-CLIENT/

ORIGINAL INSTRUCTIONS

/ 10 2024

108531