

# Chemoform CF Control 100

## Installation and Operating Instructions



**Meter and controller for chlorine  
with two dosing pumps and filter control**

**CE**

Subject to technical changes  
2010-082-63  
0217

**NOTES:**

Date: 19.09.2019

## Table of contents

<b>1</b>	<b>General Information</b>	<b>6</b>
1.1	General information	6
1.2	Notes in bold	6
1.3	Warranty	6
1.4	Safety Instructions	7
1.5	Transport damage	7
1.6	Information about carbonate hardness (CH)	8
<b>2</b>	<b>Description</b>	<b>9</b>
2.1.1	Equipment / Features	9
<b>3</b>	<b>Installation</b>	<b>10</b>
3.1	Checking the delivery	10
3.2	Assembly of the system	10
3.3	Installation drawing "Closed sample water system"	11
3.4	Installation drawing wall mounting plate with compact measuring cell	13
3.5	Connecting the measuring cell	14
3.6	The measuring cell	16
3.7	Electrodes	17
3.8	Connection of dosing pumps	17
3.9	Dosing points R 1/4"	17
3.10	pH reduce / pH raise	18
3.11	Container empty message	18
3.12	Sample water deficiency sensor	18
3.13	Heating / Solar heating	18
<b>4</b>	<b>Electrical connection</b>	<b>20</b>
4.1	Opening the unit	20
4.2	Terminals	21
4.3	Connections of filter pump	23
4.4	Connection heating / solar heating	23
<b>5</b>	<b>Device description</b>	<b>24</b>
<b>6</b>	<b>Operation and functions</b>	<b>25</b>
6.1	Changing the setting parameters (example)	25
6.2	Table of setting parameters	26
6.3	Explanations of setting parameters	28
6.3.1	Code [Parameter 0]	28
6.3.2	Set points [parameters 1, 4, 9]	29
6.3.3	Time [parameter 4]	29
6.3.4	Switching marks [parameters 21 - 37]	29
6.3.5	Release dosing [parameters 80, 81]	29
6.3.6	Release heating [parameter 82]	29
6.3.7	Slope of probe [parameter 86]	29
6.3.8	Zero point probe [parameter 87]	29
6.3.9	P-band [parameters 2, 5]	30
6.3.10	Switch-on delay [parameter 10]	30
6.3.11	Maximum dosing time (dosing time monitor) [parameters 11, 12]	30
6.3.12	Maximum daily dosing quantity [parameters 15, 16]	31

6.3.13	Dosing capacity of pumps [parameters 88, 89]	31
6.3.14	Code for calibration [parameter 92]	31
<b>7</b>	<b><u>Calibrating pH electrode and chlorine value</u></b>	<b>32</b>
7.1	Calibrating the pH electrode	32
7.2	Querying the slope / zero point of the pH electrode [parameters 86, 87]	33
7.3	Setting the disinfectant content	33
<b>8</b>	<b><u>Setting the heating and the solar heating</u></b>	<b>34</b>
8.1	Reading the water temperature [parameter 7]	34
8.2	Setting the temperature set point [parameter 9]	34
8.3	Activation of the heating	35
8.4	Changing from heating control to solar heating control (parameter 94)	35
8.5	Reading the temperature of the solar sensor [parameter 8]	35
8.6	Activation of the solar heating [parameter 94]	36
<b>9</b>	<b><u>Control of the filter pump</u></b>	<b>38</b>
9.1	Setting the time [parameter 40]	38
9.2	Setting the filter times switching marks [parameters 20 - 37]	38
9.3	24h operation	40
<b>10</b>	<b><u>Commissioning</u></b>	<b>41</b>
10.1	What to do before commissioning the system	41
10.2	Commissioning	42
10.3	Activating the complete system	42
10.3.1	Control limits	42
10.4	dinoAccess remote visualization / remote control (option)	43
10.4.1	Reset of WiFi settings	43
10.4.3	Troubleshooting	43
<b>11</b>	<b><u>Maintenance and servicing</u></b>	<b>44</b>
11.1	Cleaning and calibrating the electrodes	44
11.2	Cleaning the measuring cell	45
11.3	Wintering	45
<b>12</b>	<b><u>Alarm messages</u></b>	<b>46</b>
12.1	List of error messages:	46
12.2	Resetting of alarms	46
<b>13</b>	<b><u>Troubleshooting</u></b>	<b>47</b>
<b>14</b>	<b><u>Technical data</u></b>	<b>49</b>
14.1	General	49
14.1.1	General settings	49
14.1.2	Settings chlorine control	49
14.1.3	Settings pH control	50
14.2	Factory settings (default values)	51
14.2.1	Redox measuring and control part	51
14.2.2	pH measuring and control part	51
<b>15</b>	<b><u>Service / Basic settings</u></b>	<b>52</b>

15.1	Function: Delete data memory (reset factory settings)	52
15.2	Parameter table for service staff	52
<b>16</b>	<b><u>Maintenance and servicing - Summary</u></b>	<b>54</b>
<b>17</b>	<b><u>APPENDIX</u></b>	<b>56</b>
17.1	Liquid dosing agents for your CF Control 100 system	56
<b>18</b>	<b><u>Accessories and Spare Parts</u></b>	<b>57</b>
<b>19</b>	<b><u>Electrical connection diagram</u></b>	<b>58</b>

# 1 General Information

## 1.1 General information

This manual contains instructions for the installation, commissioning, maintenance and repair of the Chemoform control system.

The safety instructions and notes in bold type are to be observed at all times!

## 1.2 Notes in bold

In this technical information, the bold headings CAUTION, WARNING and NOTE have the following meaning:

**CAUTION:** This heading is used if failure to observe the operating or working instructions or prescribed procedures, or incorrect observation of such instructions and the like can lead to accident or personal injury.

**WARNING:** This heading is used if failure to observe the operating or working instructions or prescribed procedures, or incorrect observation of such instructions and the like can lead to damage to the equipment.

**NOTE:** This heading is used to draw special attention to important points.

## 1.3 Warranty

The manufacturer guarantees the operational safety and reliability of the system only if the following conditions are observed:

- Installation, connection, setting, maintenance and repairs are carried out by authorized and qualified specialist personnel only.
- Only original replacement parts are used for repairs.
- The CF Control 100 is used in accordance with the instructions given in this manual.

<b>WARNING:</b> The use of concentrated hydrochloric acid in the immediate vicinity of our equipment invalidates the guarantee!
---

Wearing parts are not subject to warranty (see table in chapter 17).

## 1.4 Safety Instructions

The equipment is manufactured and tested in accordance with DIN EN 61010-1 / VDE 0411 - 1 (Safety requirements for electrical equipment for measurement, control and laboratory use - Part 1: General requirements), and left the factory in a safe condition. In order to maintain this condition and to ensure a continued safe operation, the user must observe the notes and warnings contained in this technical manual. If it must be assumed that a safe operation is no longer possible, the device must be turned off and taken out of service, and made safe against accidental operation.

This is the case:

- if the system shows visible evidence of damage,
- if the system is apparently no longer in working order,
- after longer periods of storage under unfavourable conditions.

## 1.5 Transport damage

The CF Control 100 is carefully packed by us for the purpose of transport. Please check that the delivery is complete and undamaged. Any transport damage **must** be notified **immediately** (carrier).

The system must never be exposed to temperatures outside the range of -20 to +65°C (transport and interim storage).

Subject to technical changes and changes in the composition of components.

**1.6 Information about carbonate hardness (CH)**

The carbonate hardness (also acid capacity  $K_{s\ 4.3}$ ) is a factor that was not considered in the treatment of swimming pool water for a long time – it must not be confused with the total hardness of water!

Carbonate hardness only forms in connection with hydrogen carbonates. When heating water, CO<sub>2</sub> escapes and lime (calcium carbonate CaCO<sub>3</sub>, which is of low solubility) precipitates. As a result, the pH level increases, while the carbonate hardness or acid capacity, respectively, decreases. This in turn, has an adverse effect on the effectiveness of the flocculant, which is reduced, while the consumption of the pH reducer and the aggressiveness of the water increase.

Recommended values for  $K_{s\ 4.3}$  to DIN 19643:

Swimming pools  
Whirlpools

min. 0.7 mmol/l  
min. 0.3 mmol/l

approx. 2° CH  
approx. 0,8° KH

**Ideal value**  
1.8 mmol/l = 5° dH  
**carbonate hardness**

In filling-water that was treated conventionally for several weeks, the carbonate hardness permanently goes down and thus the acid capacity decreases. Even hard types of water can therefore have an insufficient acid capacity ( $K_{s\ 4.3}$ ) within a short time.

Even an adequate fresh water supply (hard water) according to DIN 19643 will not be sufficient in the long run to stabilize an ideal acid capacity. Experience has shown that pool owners try to cut down expenses by using less fresh water, in particular in the private sector.

If the fresh water is too soft, the hardness of the pool water must be increased with appropriate hardness stabilizers (carbon dioxide, carbonic acid, calcium carbonate, sodium hydrogen carbonate etc.). Ask for information about our pH stabilizer products.

**Why is it very important to comply with the values for carbonate hardness?**

**Electrodes (combination electrodes) are used for a continuous measurement of chlorine, redox and pH values. These electrodes consist of a measuring unit, a reference unit, a special electrolyte filling and a diaphragm. With the help of this diaphragm, an exchange of molecules takes place between the hydrogen in the pool water and the electrolyte molecules. The ratio of this is disturbed in case of a lack of carbonate hardness; i.e. the internal buffer of the reference system is depleted.**

Result: The electrode will not work any more and cannot be calibrated any longer!

When the electrode is replaced, the same will happen after a short time.

If an acid capacity of approx. 1.8 mmol/l (carbonate hardness = 5° dH) is maintained, a long operational safety of the electrodes (combination electrodes) can be assumed.

There are diverse measuring instruments available for measurement of the carbonate hardness.

Quick test for carbonate hardness, e.g. dinotec Easytest carbonate hardness, order no. 1420-022-00.

## 2 Description

The CF Control 100 is an easy to use measuring and control instrument for redox potential and pH.

The device measures the redox potential of the water and adjusts the chlorine content automatically to the appropriate level. External peristaltic dosing pumps are used for dosing of disinfectants.

It is optionally possible to drive a filter pump with a capacity of up to 1 kW at 230 V.<sup>1</sup> It is optionally possible to drive a heating pump / solar pump with a capacity of up to 1 kW at 230 V, or alternatively a 2-way valve.<sup>2</sup>

The pool water temperature can be measured and controlled via the heating / solar system.<sup>3</sup>

The CF Control 100 is delivered with WiFi module as standard in versions 10/2019 and later. This enables an intuitive remote visualization or remote control (extra charge) via smartphone.

### 2.1.1 Equipment / Features

- Measurement of redox (ORP)
- Control of chlorine
- Measurement and control of pH
- Measurement and control of the water temperature<sup>Fehler! Textmarke nicht definiert.</sup>
- 2 peristaltic dosing pumps
- 2 control relays
- 1 relay for connection of a filter pump
- 1 two-way contact for connection of a heating control / solar system control
- Sample water monitoring
- Numeric display without text
- Front foil with printed operation symbols and insert sheet for LED function assignment
- 2 inputs for empty signal supply units
- Software exchange via IIC-EEPROM
- Software update via IIC-EEPROM (optionally via dinoAccess app)

---

<sup>1</sup> Filter pump not included in delivery.

<sup>2</sup> Pumps / valve not included in delivery.

<sup>3</sup> Temperature sensor and components for control of the heating are not included.

### 3 Installation

For your own control and in order to get a better overview, we recommend that you follow the sequence of steps outlined below and tick the individual steps off after they have been completed.

#### 3.1 Checking the delivery

Please check that the delivery is complete and undamaged. Please notify any transport damage immediately.

#### 3.2 Assembly of the system

The CF Control 100 should be installed in a protected, easily accessible location in the plant room, preferably at eye level. To ensure proper opening of the device housing, there should be no objects within 10 cm of the mounting plate (all around). The installation position of the dosing pumps must not be higher than 1.6 m from the lowest level of the dosing tanks.

**CAUTION:** Switch the supply voltage off before opening the equipment.

Power supply of the measuring and control unit via power cord with Schuko plug.

**CAUTION:** Before the supply voltage is connected, it must be ensured that the voltage is turned off.

**WARNING:** Do not use or store volatile acids in the immediate vicinity of the unit.

**The use of concentrated hydrochloric acid in the immediate vicinity of our equipment invalidates the guarantee!**

3.3 Installation drawing "Closed sample water system"

Fig. 3-1

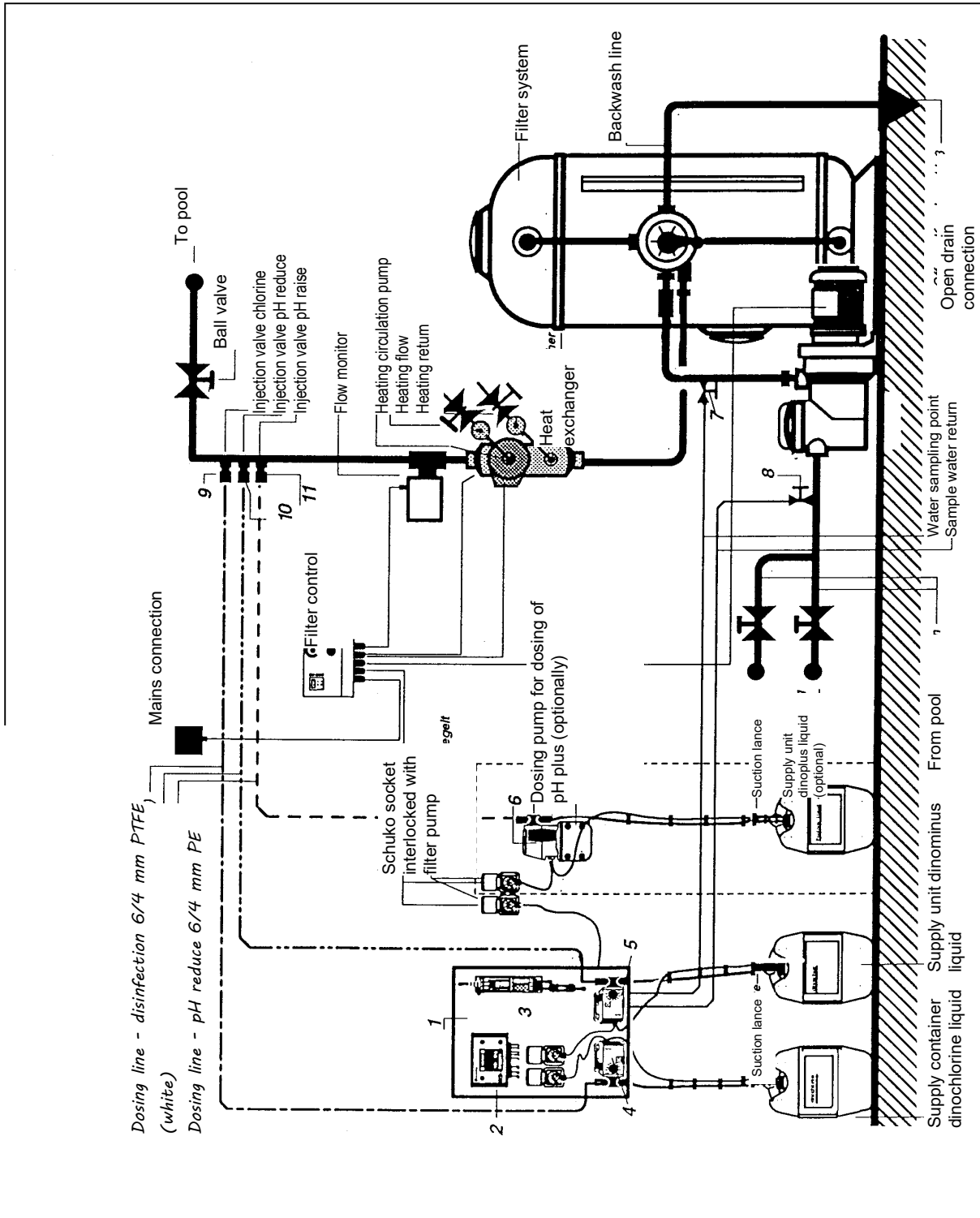

**NOTE:**

**Please observe the information given in the section water sampling!**

**Legend**

- 1 Plastic wall mounting plate
- 2 CF Control 100
- 3 Compact measuring cell
- 4 Dosing pump chlorine
- 5 Dosing pump pH Minus
- 6 Dosing pump pH Plus (optionally)
- 7 Water sampling
- 8 Sample water return
- 9 Dosing point chlorine
- 10 Dosing point pH Minus
- 11 Dosing point pH Plus

3.4 Installation drawing wall mounting plate with compact measuring cell  
Fig. 3-2

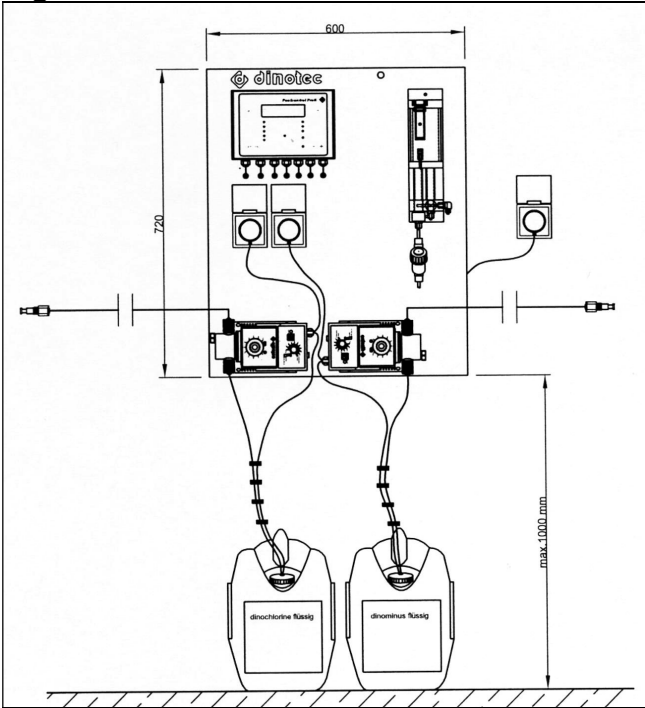

3.5 Connecting the measuring cell

Fig. 3-3

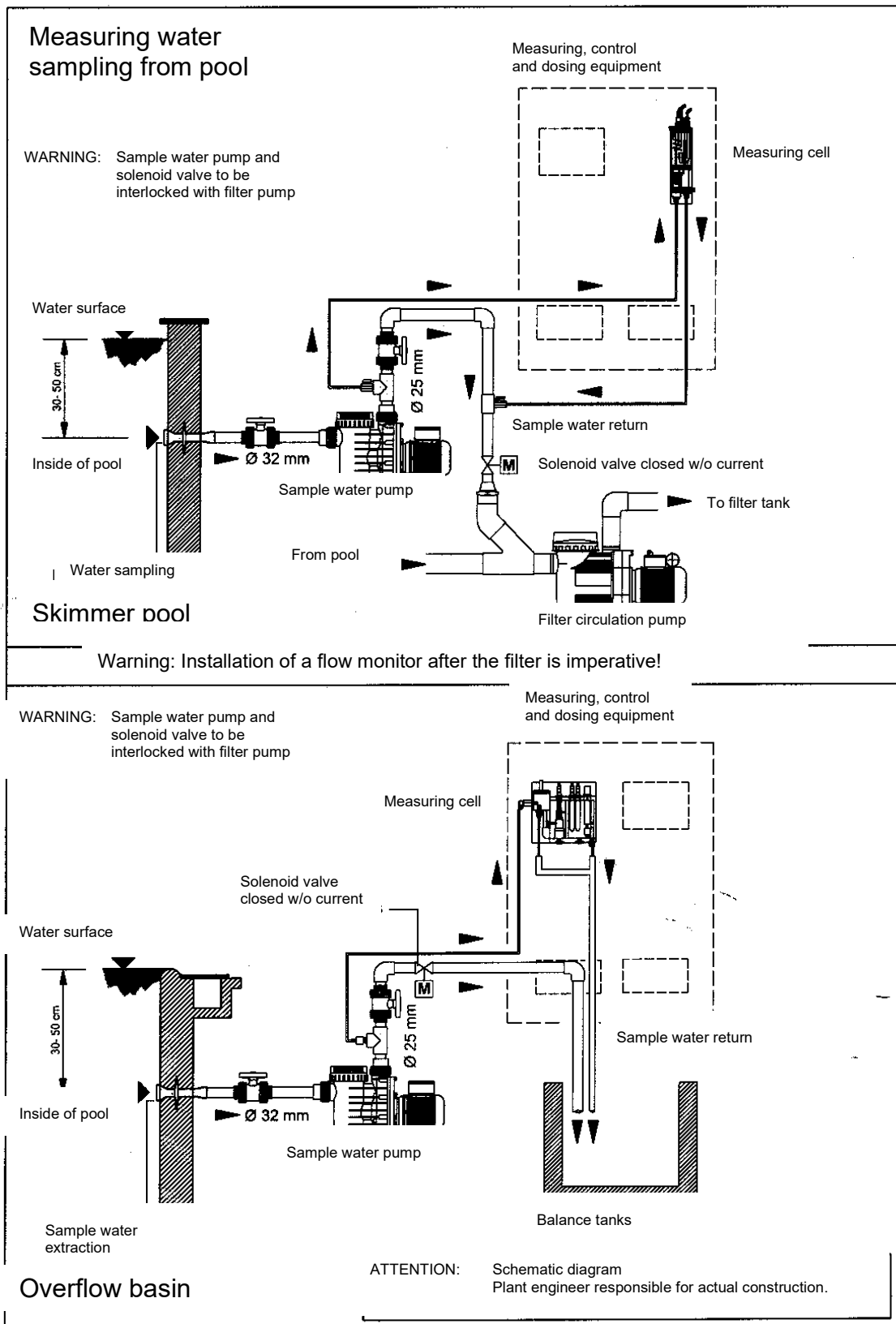

The water sampling is to be arranged in such a way that representative sample water is available at all times.

- a) Extraction from the pool through suitable borings in the pool wall, about 30-50 cm below the water surface. (Idea situation!)
- b) Extraction from the pressure side of the circulation pump, in front of the filter. It must be ensured in this case that the sample water is not altered/manipulated by fresh water. If required, the sample water is to be taken from the floor suction circulation.
- c) Extraction from the overflow gutter.

**WARNING: Check that water is overflowing at all times!**

<b>ATTENTION:</b> Failure to comply with the assembly instructions can result in measurement errors.
--

If the sample water pressure is less than 0.1 bar, or the sample water line is exceeding a length of 10 m, a sample water pump must be installed.

<b>WARNING:</b> A fiber filter is installed in the sample water line to prevent the measuring cell from getting clogged by dirt. The fiber filter must be cleaned at regular intervals (every 1-2 weeks) or more frequently, if required (for example in case of outdoor pools)!
--

<b>WARNING:</b> Please observe the detailed description for the setting of the measuring cell. The initial pressure at the measuring cell should not exceed 1 bar.
--

3.6 The measuring cell

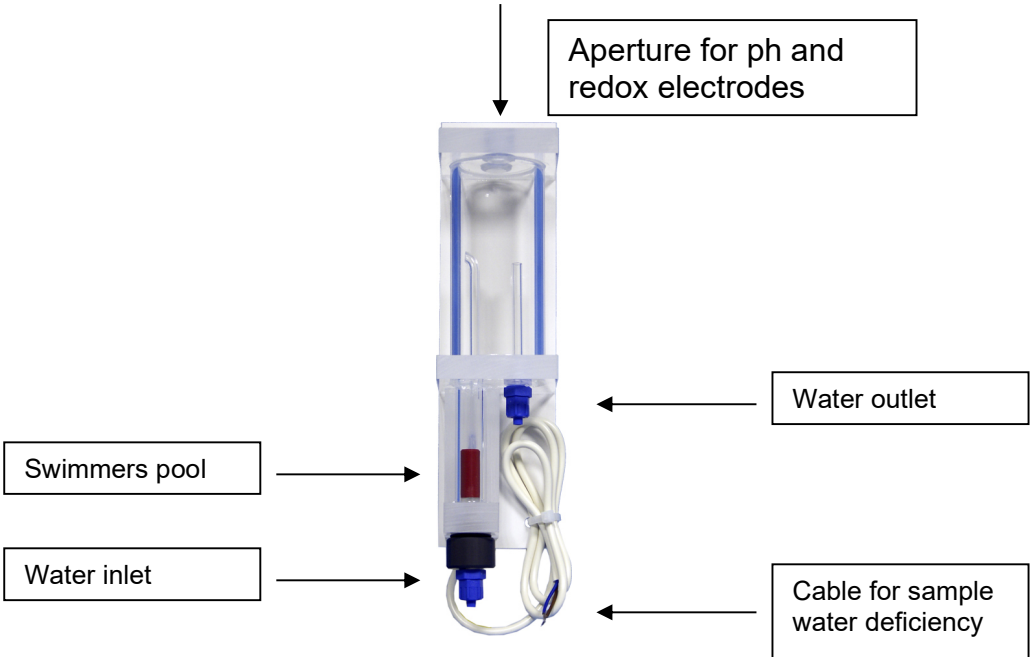

### 3.7 Electrodes

Electrodes to be used: 0161-101-01 pH combination electrode (**length 120 mm**) and 0111-103-00 Redox electrode without reference system.

Take the electrodes out of the containers and remove the protective caps. Insert the measuring electrode into the measuring cell and screw in **hand-tight**. After that, connect the black measuring cable to the electrode. Please observe the labelling on the connection lines. Cable connections and plugs must be protected from damp to avoid corrosion.

**NOTE:** Take care of the O-rings on the electrodes when connecting the measuring cables!

**NOTE:** The use of organic chlorine preparations can produce deviations between instrument readings and DPD measurements. For this reason, we recommend the use of inorganic chlorine preparations (**e.g. dinochlorine liquid or calcium hypochlorite**).

### 3.8 Connection of dosing pumps

The dosing pumps are assembled and connected electrically at the works. The parameters required in the CF Control 100 for control are preset according to the connected dosing pumps.

Please observe the separate manual for the used dosing pumps.

### 3.9 Dosing points R 1/4"

Install the dosing line (included in the delivery) to the injection points.

**WARNING:** The injection points for disinfection (9)<sup>4</sup> and for pH correction (10, 11) are installed in the nozzle line on the pure water side (to the pool) after the heating (or after the return flow from the solar absorber) and after the flow monitor. That is, in the direction of flow, first pH correction and then disinfection.

**WARNING:** Never place the dosing lines close to heating pipes and avoid sharp angles.

The dosing line PE yellow 6/4 mm is intended for dosing of pH Minus liquid, pH Plus liquid concentrate and flocculant.

The dosing line PTFE white 6/4 mm is intended for dosing of liquid chlorine or liquid active oxygen.

**CAUTION:** Never use dosing lines alternately, e.g. chlorine/pH Minus.

<sup>4</sup> For descriptions/identification, see Fig. 3-1

### 3.10 pH reduce / pH raise

The CF Control 100 is delivered with a dosing pump for correction of the pH level. By default, the pump is set to the control mode pH reduce; however, this can be changed to pH raise.

<b>NOTE:</b>	pH reduce - when the pH level is too high (use of pH minus liquid). pH raise - when the pH level is too low (use of pH plus liquid).
--------------	---

### 3.11 Container empty message<sup>5</sup>

If you use suction lances with a container low-level indicator you can connect these according to the following terminal diagram:

- Terminal 17-18: empty signal input chlorine
- Terminal 19-20: empty signal input pH corrector

The container low-level indicator must work as normally open contact.

### 3.12 Sample water deficiency sensor

Depending on the version, the measuring cell is fitted with a float (red) and a reed contact switch. When the sample water stops circulating, the float drops down and the CF Control 100 deactivate all dosing processes as well as the heating. The cable of the measuring cell is connected to input contacts 15/16 (sample water deficiency) at the works.

When a sample water deficiency occurs, the message "Sample water deficiency" is displayed by means of an LED that lights after a delay of 10 seconds. When the sample water circulates again, the previous operating mode is restored after 10 seconds. Please note that the switch-on delay starts when the device is switched on again and that the dosing processes only restart after elapse of this delay.

### 3.13 Heating / Solar heating

The CF Control 100 has a potential-free two-way contact that can be used for switching the heating or solar heating on.

---

<sup>5</sup> Container empty signal equipment is not included

Pool heating via solar collectors

- 1.) Control via 2-way motorised valve 230 V 1N- AC 50/ 60 Hz

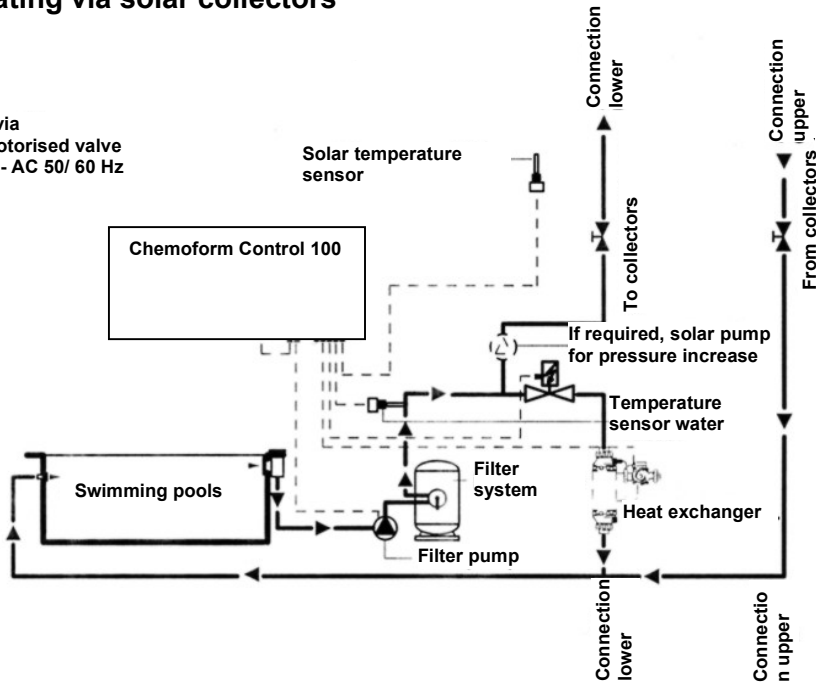

- 3.) Control via solar pump 230 V 1N- AC 50/ 60 Hz, max. 1.0 kW via separate solar circulation

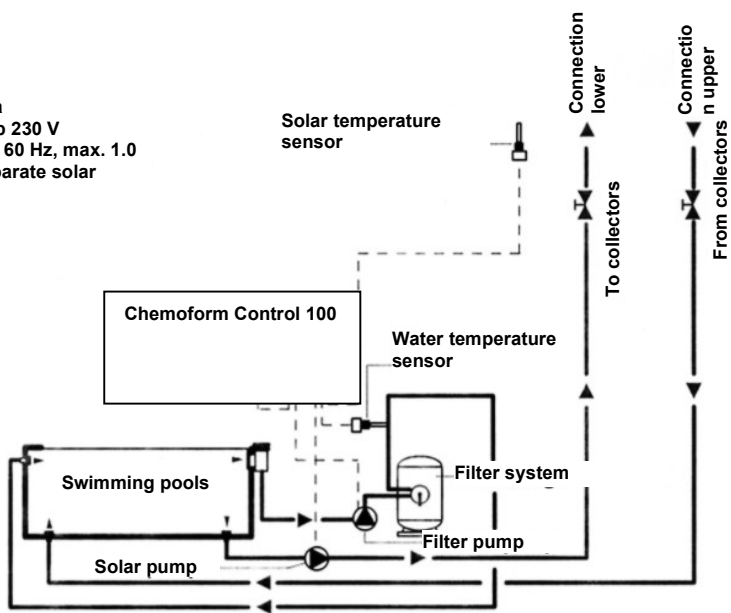

## 4 Electrical connection

### 4.1 Opening the unit

The terminal box for the connections is located in the lower quarter of the housing. To open the housing, loosen the two screws as shown in the photo.



The two measuring cables for redox and pH electrodes are connected at the works. These connections are located in the upper right corner in the housing. If you have to work on these connections, remove the four clips using a suitable screwdriver (width) to reach the housing screws. Remove the housing cover with care.

**WARNING:** Remove the housing cover with care, otherwise the connection cable to the main board may break away.

4.2 Terminals

NOTE: The terminal layout plan is included in chapter 19 (Appendix)

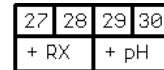
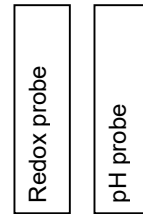

These four terminals are located in the upper right corner in the housing.

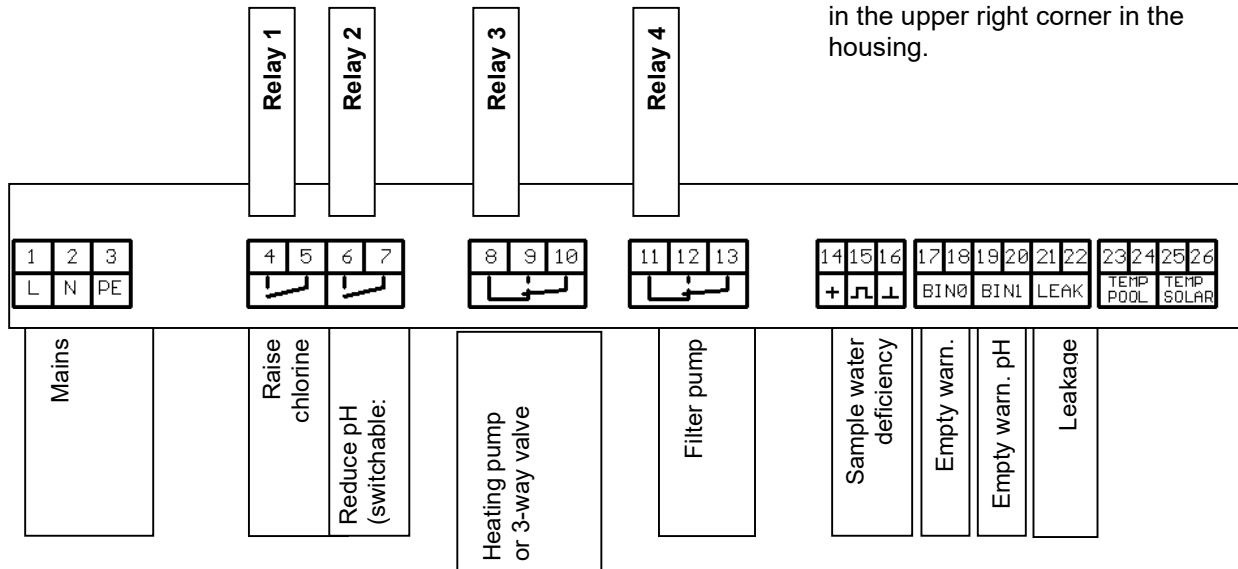

Tab. 1<sup>6</sup>

No.	Terminal	Function
1	L	Power input 115V ±10% or 230V ±10% 50/60Hz (Automatic switching)
2	N	
3	PE	
4	NO	Phase from wire connector box L
5	COM	Output relay 1: raise chlorine
6	NO	Phase from wire connector box L
7	COM	Output relay 2: pH reduce (switchable to pH raise in device via the menu navigation)
8	NC	Output relay 3: connection 3-way valve "Closed"
9	NO	Output relay 3: connection for heating pump or connection 3-way valve "Open"
10	COM	Phase from wire connector box L
11	NC	Not assigned
12	NO	Output relay 4: connection for filter pump
13	COM	Phase from wire connector box L

<sup>6</sup> Explanations of the table: see next page

14	+24V	Not assigned
15	Pulse	Sample water deficiency, potential-free, normally open contact
16	GND	
17	BIN0	Empty signal input chlorine, potential-free, normally open contact
18	BIN0	
19	BIN1	Empty signal input pH correction chemicals, potential-free, normally open contact
20	BIN1	
21		Leakage detection from dosing pumps, normally open contact, not assigned
22		
23		Connection water temperature sensor PT1000
24		
25		Connection solar temperature sensor PT1000
26		
27	+	Measuring input redox
28	-	
29	+	Measuring input pH
30	-	

Explanations:

- NC: Normally Closed, output works as normally closed contact
- NO: Normally Opened, output works as normally open contact
- COM: Common, shared connection
- From wire connector box N, L , PE: There are three 5-pole wire connector boxes connected in the unit for power distribution (see diagram, chapter 19)

**Note:** The plugs can be removed for an easier installation of the connection cables outside the terminal box.

**Note:** A resistor is installed at the works for terminal 23-24 (water temperature sensor). When connecting the Pt1000, this resistor must be removed.

### 4.3 Connections of filter pump

If the CF Control 100 is intended to drive a filter pump, it is switched via relay 4 (terminal 12-13). The maximum capacity of the filter pump must be 0.5 kW at 230 V.

**Note:**

When using 400 V pumps, an additional three-phase contactor with motor protection and the following ampere scale is required:

1.0 - 1.6 A, 400 V Art. no.: 0960-277-00

1.6 - 2.4 A, 400 V Art. no.: 0960-278-00

2.4 - 4.0 A, 400 V Art. no.: 0960-279-00

4.0 - 6.0 A, 400 V Art. no.: 0960-280-00

6.0 - 9.0 A, 400 V Art. no.: 0960-281-00

### 4.4 Connection heating / solar heating<sup>7</sup>

The CF Control 100 can drive a heating or a solar heating system. When there is a demand for heating, a **potential-free two-way contact** is switched. Connections: terminals 8 and 9, terminal 10 is used for the phase coming from the wire connector box. This can be used to connect a heating pump (cl. 9), a motorised ball valve or a 3-way solenoid valve (terminal 8 „Open“, terminal 9 „Closed“). The maximum capacity of the heating pump must be 0.5 kW at 230 V.

---

<sup>7</sup> The solar temperature sensor is not included.

## 5 Device description

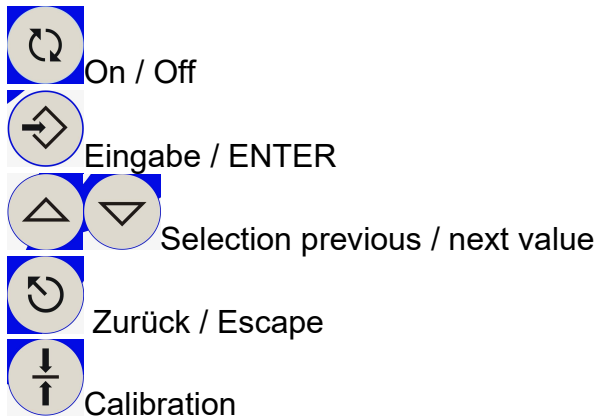
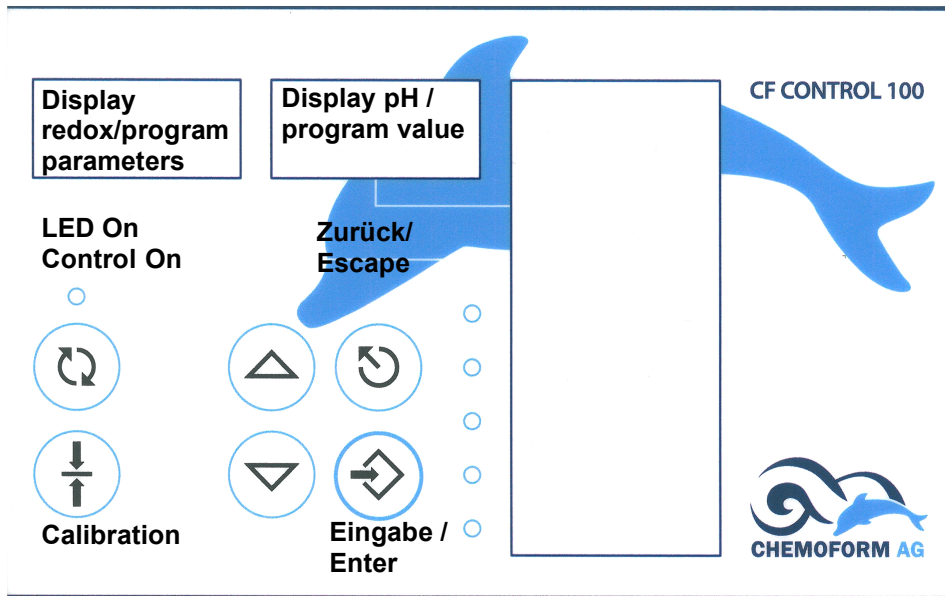

During operation, the following is displayed:

- Measured redox potential on the left (650)
- Measured pH value on the right (7.22)

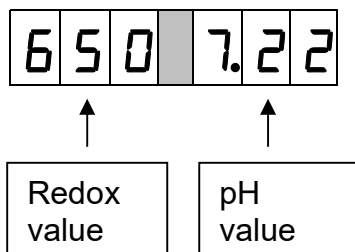

## 6 Operation and functions



To switch the dosing function on or off, press

All other settings are accessible via so-called setting parameters.

These are explained in the "Table of setting parameters" in the next section. The procedure is always the same. An example is used to demonstrate the steps.

### 6.1 Changing the setting parameters (example)

It is assumed that you want to change the set point for the control of pH:

- 1) Look for the appropriate entry in the table below, in this case at parameter 1:

Parameter	Function / Value
s	
1	Set point pH (6.5-8.5)



- 2) Press Eingabe / ENTER:

The display changes: Instead of the redox and pH value, the parameters and their functions or values are displayed.

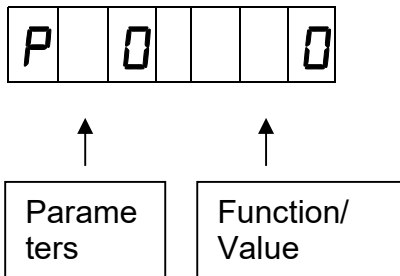

- 3) Press or to select the desired parameter on the **left**:

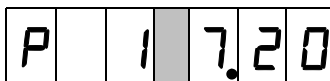

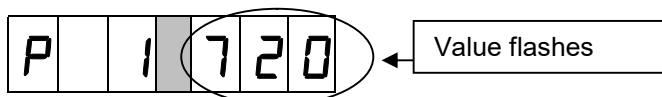

- 4) Confirm your selection by pressing , the value on the right starts flashing.

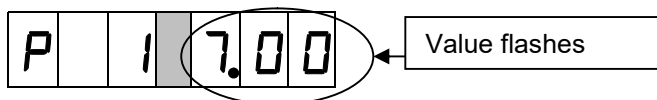

- 5) Press or to select the desired parameter **on the right**:



6) Confirm your selection by pressing , the value on the right stops flashing, which means that the value has been stored.

After that, you can use  or  to adjust further parameters or you can quit the parameter settings by pressing .



## 6.2 Table of setting parameters

Table 1 Code A (00)

Parameters	Values - Setting limits	Factory setting
00	CODE	
01	Set point pH (6.5-8.5)	7.2 pH
04	Set point redox (350-950)	600 mV
07	Measured value water temperature in 0.1°C	only display
08	Measured value temperature at solar absorber in 0.1 °C (is only displayed when solar heating has been activated)	only display
09	Setpoint water temperature in 0.1°C (5-40)	28 °C
20	Switching mark 1 hour (0-23)	
21	Switching mark 1 minute (0-59)	
22	Switching mark 1 condition ---: Switching mark inactive <i>On</i> : Filter pump ON <i>OFF</i> : Filter pump OFF	---
25	Switching mark 2 hour (0-23)	
26	Switching mark 2 minute (0-59)	
27	Switching mark 2 condition ---: Switching mark inactive <i>On</i> : Filter pump ON <i>OFF</i> : Filter pump OFF	---
30	Switching mark 3 hour (0-23)	
31	Switching mark 3 minute (0-59)	

Parameters	Values - Setting limits	Factory setting
32	Switching mark 3 condition --- : Switching mark inactive ON: Filter pump ON OFF: Filter pump OFF	---
35	Switching mark 4 hour (0-23)	
36	Switching mark 4 minute (0-59)	
37	Switching mark 4 condition --- : Switching mark inactive ON: Filter pump ON OFF: Filter pump OFF	---
40	Time in hours (0 - 23)	
41	Time in minutes ( 0 - 24)	
80	Release dosing chlorine (relay 1) 0: not released 1: released	1
81	Release dosing pH reduce (relay 2) 0: not released 1: released	1
82	Release heating (relay 3) 0: not released 1: released	1
84	pH control direction relay 2 0: reduce 1: raise	0
85	Probe voltage pH (in mV)	only display
86	Slope of pH probe <sup>8</sup>	only display
87	Zero point pH probe <sup>Fehler! Textmarke nicht definiert.</sup>	only display
98	Software version: serial number	only display
99	Software version: year	only display

Table 2 Code B (NN) in addition:

Parameters	Function	Factory setting
02	P-band pH (0.2 – 3)	1 pH
03	Hysteresis pH (0.0 – 1.0)	0.1 pH
05	P-band redox (20-300)	100 mV
10	Switch-on delay dosing and heating in min. (1-30) Switch off = 0	5min
11	Max. dosing time relay 1 in min (1-90) No monitoring = 0	60 min.

<sup>8</sup> Reset of calibration values (86,87) via parameter 00 with function 999 (see chapter 15.1)

Parameters	Function	Factory setting
12	Max. dosing time relay 2 in min (1-90) No monitoring = 0	60 min.
15	Max. daily dosing quantity relay 1 in 0.1 liter, (1-300) No monitoring = 0	0
16	Max. daily dosing quantity relay 2 in 0.1 liter, (1-300) No monitoring = 0	0
50	Mode relay 1: „0“ = On/ Off; „1“ = Pulse frequency „2“ = Pulse / Pause	2
55	Mode relay 2: „0“ = On/ Off; „1“ = Pulse frequency „2“ = Pulse / Pause	2
88	Max. dosing capacity pump DES in 0.1 l/h (5-80)	3 l/h
89	Max. dosing capacity pump pH in 0.1 l/h (5-80)	3 l/h
90	Operating mode <sup>9</sup>	1
91	Disinfection mode <sup>9</sup>	1
92	Blocking the calibration 0: A,B,C - 1: B,C	0

Attention: Please do not change the parameters in the fields highlighted in grey in this manual.

### 6.3 Explanations of setting parameters

#### 6.3.1 Code [Parameter 0]

There are 3 access levels that you can access by using codes. This is to protect the device from unauthorized operation.

- A) Code A - 00: End user code
- B) Code B – NN.: Code for pool dealers / service staff
- C) Code C – NN: Code for dinotec factory service.

The table in chapter 6.2 lists the setting parameters that are available in different access levels.

<sup>9</sup> After changing the mode, a different manual is applicable!

Change code: via parameter 00 as described before.

### 6.3.2 Set points [parameters 1, 4, 9]

Here you can enter the desired set points for redox, pH and pool water temperature.

### 6.3.3 Time [parameter 4]

When you connect a filter pump for time-controlled operation, a time must be entered first. Please refer to chapter 9.1 for more information.

### 6.3.4 Switching marks [parameters 21 - 37]

You can switch a connected filter pump on and off punctual to the minute up to four times a day. This is implemented by setting switching marks and assigning times and conditions to these marks. Please refer to chapter 9.2 for more information.

### 6.3.5 Release dosing [parameters 80, 81]

You can deactivate individual dosing processes. If the value for dosing output parameters is set to 1, the dosing is switched on, with value 0 the dosing is switched off.

Parameter 80, raise chlorine (0- off; 1 on)

Parameter 81, reduce pH (0- off; 1 on)

### 6.3.6 Release heating [parameter 82]

You can switch the heating pump / control for the 3-way valve off separately. If the value for the control output parameter is 1, the heating pump is switched on, with value 0 the heating pump is switched off. Alternatively, the 3-way valve is set/not set. Parameter 82, heating pump / 3-way valve (0 off, 1 on)

### 6.3.7 Slope of probe [parameter 86]

The voltage that a pH electrode releases per pH. A new pH electrode can generate a maximum of 58.2 mV/pH. During operation, the slope of the electrode is reduced over time. As soon the slope falls below 50mV/pH, the electrode should not be used any longer.

The slope of the probe is recalculated every time the electrode is calibrated.

### 6.3.8 Zero point probe [parameter 87]

Physically, the zero point of a new pH electrode is 7.00 pH. This value can deviate slightly due to temperature influences etc. (max. +/- 0.10 pH). During operation, the zero point can shift upwards or downwards. If the deviation (from 7.00 pH) exceeds 1 pH (= +/- 58mV), the pH electrode should not be used any longer.

The zero point of a probe can be queried with parameter 87; it is recalculated every time the electrode is calibrated.

**6.3.9 P-band** [parameters 2, 5]

A virtual control range is defined around the setpoint, the so-called P-band (proportional band). If the measured value is outside this P-band, dosing is carried out with 100 % of the dosing capacity. If the measured value exceeds the P-band, dosing is reduced in line with the P-band until the dosing stops altogether on reaching the set point.

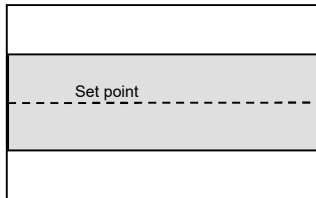

**6.3.10 Switch-on delay** [parameter 10]

After any interruption in the operation (e.g. initial commissioning, backwashing or activation of the circulation), it normally takes some time until representative sample water is available. In order to prevent a resulting overdosing, a switch-on delay time should be set.

The measuring function is still active, but the dosing pumps remain switched off. A switch-on delay of 5 minutes is set at the works.

**Diode "Dosing on" flashing = switch-on delay active**

The switch-on delay is deactivated or changed via parameter 10 (service code required).

The switch-on delay effects all dosing outputs.

It is restarted every time an error is removed that was triggered by a measuring water deficiency.

**6.3.11 Maximum dosing time (dosing time monitor)** [parameters 11, 12]

The dosing time monitor checks for each dosing output whether the dosing is capable of reaching the last third of the P-band around the set point within the time set here. If this is not the case, it is assumed that there may be an error (broken hose etc). For safety reasons, the dosing function is switched off in this case. The following is displayed:

- E-4: Dosing time chlorine exceeded
- E-5: Dosing time pH raise exceeded

When the dosing time monitor has responded, you enable (release) the dosing again

in this menu by pressing  after the fault has been removed.

The dosing time monitor is restarted each time the dosing is restarted.

If the parameter for the maximum dosing time is set to 0, a monitoring of the appropriate dosing output is switched off.

### 6.3.12 Maximum daily dosing quantity <sup>10</sup> [parameters 15, 16]

It is possible to specify the max. daily dosing quantity separately for each dosing output. The CF Control 100 adds up the dosing quantities which the respective pump delivers. If the quantity is exceeded within a calendar day, a "Dosing time monitor" alarm is triggered. Dosing is completely deactivated. The alarm must be reset using

the  button.

If the parameter for the maximum daily dosing quantity is set to 0, a monitoring of the appropriate dosing output is switched off.

### 6.3.13 Dosing capacity of pumps [parameters 88, 89]

If you establish that there are overshoots in the control of chlorine and pH (overshooting of actual values), or that set points are not reached or not reached within a reasonable time, you can try and use these settings to adapt the dosing capacities of the pumps to your pool size.

### 6.3.14 Code for calibration [parameter 92]

You can prevent someone unauthorized from carrying out a pH calibration. Go to the setting parameters as described above and select parameter 92; code B must be set first:

Parameter s	Function	Factory setting
92	Code for calibration: 0: A,B,C - 1: B,C	0

If you select 0, the calibration can be carried out with any of the three codes; if you select 1, the process is restricted to authorization codes B and C (specialist dealer - dinotec service staff). A calibration with user code A is no longer possible in this case.

<sup>10</sup> This function is only recommended when using the water guard dosing 100 pumps!

## 7 Calibrating pH electrode and chlorine value

### 7.1 Calibrating the pH electrode

The pH electrode is to be re-calibrated at regular intervals, e.g. every 4 weeks and after each commissioning. This informs the CF Control 100 about the current operating status of the probe, which changes during operation. You need calibration solutions pH4 and pH7 with the red and green covers to carry out a calibration.

**WARNING:** *Flush the electrode with water and dry it with a soft paper towel or clean it with a probe cleaner (0181-184-01) before immersing it in the buffer solution.*

**NOTE:** *Please observe the information about maintenance and servicing of the electrodes (enclosed with the electrode).*

The system must be switched off  before you carry out a calibration. The LED must be off.

Immerse the pH electrode in buffer solution 7.0 and wait until the measured value does not change any more.

Press  for at least 3 seconds - the following is displayed:

C	A	L		P	H	7
---	---	---	--	---	---	---

Dry the pH electrode with a soft paper towel.

Immerse the pH electrode in buffer solution 4.0 and wait until the measured value does not change any more.

Press  again **for at least 3 seconds** - the following is displayed:

C	A	L		P	H	4
---	---	---	--	---	---	---

The calibration is complete.

The calibration process is not started if

- dosing is switched on,
- the set authorization code does not permit this,
- the voltage of the pH electrode is outside the range of
  - -58mV and + 58mV for pH=7
  - and
  - +116mV and +232mV for pH=4

If the voltage is outside the above range during the calibration process, the following error message is displayed:

C	A	L		E	r	r
---	---	---	--	---	---	---

### 7.2 Querying the slope / zero point of the pH electrode [parameters 86, 87]

It is possible to query data about slope and zero-point deviation of the pH electrode. The query is made via the menu navigation. Choose parameter 86 to display the slope, and parameter 87 to display the zero-point deviation.

**NOTE:** When the measured slope is **< 50 mV and > 80 mV**, an alarm message is triggered.

The displayed zero point should be within a range of **7 ± 1 pH**.

### 7.3 Setting the disinfectant content



Add chlorine manually to the pool or whirlpool until the desired content (e.g. 0.3 – 0.8 mg/l free chlorine) is reached.

**NOTE:** For previously non-chlorinated water, you will need approx. 30 - 40 ml of **dinochlorine liquid** per 10 m<sup>3</sup> pool volume.

The content is to be checked with a suitable measuring instrument (e.g. Pooltester or Photolyser). Once the required content has been checked and found to be constant over several measurements, the CF Control 100 can be calibrated.



The system is set to a redox set point of 600 mV at the works. This value must be adjusted until it corresponds to your current and correct disinfectant content.

Please read the currently displayed value for redox, which could be 670 mV, for example.

Press the  Eingabe / ENTER button and choose parameter P 4 (confirm with ).

P		4		6	7	0
---	--	---	--	---	---	---

Adjust the set point (on the right) to the redox value read in

the display before by pressing  or  (in this example to 670).

Press  to return to the display level.

The CF Control 100 will then keep your disinfectant content on the current level.

## 8 Setting the heating and the solar heating

You can heat your pool water via your domestic heating system or alternatively via a solar system<sup>11</sup>.

A mixed operation with both system is not possible.

The following chapters 8.1 and 8.2 are applicable for both heating modes:

### 8.1 Reading the water temperature [parameter 7]

Press the  Eingabe / ENTER button and choose parameter P 7.



P 7 28.0



The water temperature is displayed in tenth of a degree.

Press  to return to the display level.

**NOTE:** Since the water temperature is not measured right in the swimming pool / whirlpool, it is possible that there are minor deviations between the displayed temperature and the water temperature measured right in the pool.

### 8.2 Setting the temperature set point [parameter 9]

Press the  Eingabe / ENTER button and choose parameter P 9 (confirm with ).

P 9 28.0 Adjust the set point to the required temperature using  or , in this case 28°C.

The setting is made in tenth of a degree.

 Eingabe / ENTER

Press  to return to the display level.

The CF Control 100 will then keep your water temperature at this value.

<sup>11</sup> If a solar heating is employed, a second temperature sensor PT 1000 is required, which is not included.

### 8.3 Activation of the heating

The heating circulation is connected by the CF Control 100 when the following conditions are fulfilled:

1. The actual temperature of the pool water is below the adjusted set point temperature for one minute.
2. The set switch-on delay has elapsed.
3. Sample water is circulating.
4. The filter pump is switched on.

When the water temperature has exceeded the set point for more than a minute, the heating is deactivated.

### 8.4 Changing from heating control to solar heating control (parameter 94)

Press the  Eingabe / ENTER button and choose parameter P 94. When the value on the right is set to 0, only heating is activated.

P	9	4				0
---	---	---	--	--	--	---

 / ENTER

Set the value on the right to 1; as a result, the solar operation is activated:

P	9	4				1
---	---	---	--	--	--	---

 / ENTER

Press  to return to the display level.

**NOTE:** You can select either the heating operation or alternatively the solar operation.

**WARNING:** It is mandatory that a second solar temperature sensor is available for the solar operation. It should always be positioned at the highest place of the solar system. <sup>12</sup>

### 8.5 Reading the temperature of the solar sensor [parameter 8]

Press the  Eingabe / ENTER button and choose parameter P 8.

P		8		4	2	0
---	--	---	--	---	---	---

The temperature is displayed in tenth of a degree.

<sup>12</sup>The solar temperature sensor is not included.

Press  to return to the display level.



## 8.6 Activation of the solar heating [parameter 94]

The solar heating is connected by the CF Control 100 when the following conditions are fulfilled:

1. The heating is changed to solar heating [P 94]
2. The set switch-on delay has elapsed.
3. Sample water is circulating.
4. The filter pump is switched on.
5. The actual temperature of the pool water is below the adjusted set point temperature for one minute.
6. The temperature at the solar absorber is higher than a temperature specified by you for one minute.

The purpose of point 6 is to ensure that the solar energy is sufficient to supply the required heat energy.

We assume in our example that the solar heating is to be activated when the temperature at the solar absorber is 16 °C above the pool water temperature. In this case, enter this difference (16°C) as value for parameter P 95.

Press the  Eingabe / ENTER button and choose parameter P 95 (confirm with ).

Then set the difference value that you have determined.

P	9	5			1	6
---	---	---	--	--	---	---

 Eingabe / ENTER

Press  to return to the display level.

When the temperature at the solar absorber permanently goes down for 2°C below this switch-on temperature, the solar heating is switched off again. (This is also the case if one of the other pre-conditions described before is not fulfilled any longer).

The solar absorber must be filled with water to be able to put the solar system into operation.

**CAUTION:** The CF Control 100 deactivates the solar absorber when the adjusted set point for the pool water temperature is reached. It is possible therefore that the cooling of the collector is not always sufficient, which applies especially to hot countries. The customer must safeguard against a possible overheating that could damage the solar system. <sup>13</sup>

**NOTE:** If you do not want the solar collector to be deactivated, adjust the set point for the pool water to a value that is above the measured temperature of the water in the collector.



---



<sup>13</sup> For further information refer to the product assembly and service instructions for the solar system.

## 9 Control of the filter pump

### 9.1 Setting the time [parameter 40]

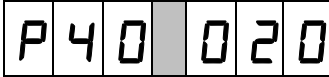

When you connect a filter pump for time-controlled operation, a time must be entered first. In this example, the clock is to be set to 20:16.

Press the  Eingabe / ENTER button and choose parameter P 40 to set the hour value (confirm with ).

 Set the value (right side) using  or  to the desired hour, e.g 20:00 h.

 Eingabe / ENTER

Select parameter 41 for the minute value and set the desired time on the right side. In this example, the time is 20:16:

  Eingabe / ENTER.



Press  to return to the display level.



Note: If the CF Control 100 is disconnected (switched off) from the mains, the clock is operated via battery.

### 9.2 Setting the filter times switching marks [parameters 20 - 37]

You can switch a connected filter pump on and off punctual to the minute up to four times a day. This is implemented by setting switching marks and assigning times to these marks. The switching marks can be set to the conditions "On" [ON], "Off" [OFF] or "Inactive" [---]. These switching marks are evaluated at the corresponding times, and the pump is connected, if required.

The following is an example for setting and activating switching mark 1 to turn-on time 20:15.

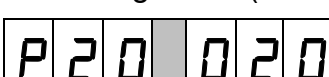
Press the  Eingabe / ENTER button and choose parameter P 20 to set the switching mark. (confirm with ).

 Set the value (right side) using  or  to the desired hour, e.g 20:00 h.



Eingabe / ENTER

Choose parameter 21 for a setting of the minutes.

P	2	1	0	1	5
---	---	---	---	---	---

Set the value using  or  to the desired minute, e.g. 15 min.

Eingabe / ENTER

You set the desired switching status with parameter 22.

P	2	2	0	n	
---	---	---	---	---	--



Eingabe / ENTER

At this point, you can set further switching marks according to the following table, or

press  to quit the parameter settings:

Parameters	Function / Value	Factory settings
20	Switching mark 1 hour (0-23)	
21	Switching mark 1 minute (0-59)	
22	Switching mark 1 condition ---: Switching mark inactive On: Filter pump ON OFF: Filter pump OFF	---
25	Switching mark 2 hour (0-23)	
26	Switching mark 2 minute (0-59)	
27	Switching mark 2 condition ---: Switching mark inactive On: Filter pump ON OFF: Filter pump OFF	---
30	Switching mark 3 hour (0-23)	
31	Switching mark 3 minute (0-59)	
32	Switching mark 3 condition ---: Switching mark inactive On: Filter pump ON OFF: Filter pump OFF	---
35	Switching mark 4 hour (0-23)	
36	Switching mark 4 minute (0-59)	
37	Switching mark 4 condition ---: Switching mark inactive On: Filter pump ON OFF: Filter pump OFF	---

The switching marks can be set in any sequence; you have to observe, however, that the filter times do no overlap and the switching status On or Off alternate in chronological order, e.g.

Switching mark 3 10:00 OFF  
 Switching mark 1 08:00 ON  
 Switching mark 4 16:00 ON  
 Switching mark 2 22:00 OFF

In this example, the filter pump would run daily from 8:00 to 10:00 and from 16:00 to 22:00.

### 9.3 24h operation

Set the following switching marks for a 24 h-operation of the filter system:

Parameters	Function / Value	Setting
22	Switching mark 1 condition	0n
27	Switching mark 2 condition	0n
32	Switching mark 3 condition	0n
37	Switching mark 4 condition	0n

**Warning:** If the pump should run for 24 hours, always set this as described before, and **not** by pressing the  button for a longer time.

## 10 Commissioning

### 10.1 What to do before commissioning the system

For all swimming pools and whirlpools, it is very important that pool hydraulics, water system and overall technical equipment are properly planned, constructed and, of course, operated accordingly. The following points are of particular importance in this respect:

- Compliance with our recommendation of a minimum operating time of the filter system/measuring, control and dosing system of 12 hours per day.
- Filter backwash at least once a week, or more often in case of increased usage.
- Removal of fine dirt particles by means of flocculation.
- Regular pool cleaning with a suction machine (e.g. AquaCat).

If swimming pool and technical equipment are already existing and you want to switch to the CF Control 100 automatic measuring, control and dosing system, the following is to be considered:

- Check the complete system with respect to its technical operation including the required pool hydraulics.
- The existing pool water should preferably be drained off if it has been in the pool for more than 6 months and/or if the water was treated with organic chlorine or alternative products before. Please consult your service partner.
- The pool has to be thoroughly cleaned before being re-filled with fresh water.
- Check the filter material and replace it, if necessary.
- Wash the pool surface (particularly important in case of foil surfaces) with a suitable algaecide (e.g. dinolgin, dinozon, dinocid special) before re-filling.
- Then fill immediately with fresh water and put into operation.

When all dosing systems are connected, connect the unit to the mains.



When the LED „Dosing — on“ lights, switch the dosing off by pressing . Open the ball valves (0181-178-01) of the measuring cell at the water sampling point and the sample water return completely.

**WARNING:** Adjust the flow at the measuring cell.

## 10.2 Commissioning

Please proceed in the following sequence for commissioning the system:

- 1) Set the time (chapter 9.1)
- 2) Set the filter times switching marks (chapter 9.2)
- 3) In case of solar heating: change to solar and set up (chapter 8)
- 4) Calibrate the pH electrode (chapter 7.1)
- 5) Set the disinfectant content (chapter 7.3)
- 6) Adjust the set points for pH, chlorine and water temperature (chapters 6.2 and 8.2)

## 10.3 Activating the complete system

Once you have ensured that all instructions up to this point have been observed and that the CF Control 100 is correctly set and calibrated, you can switch on the dosing pumps: As soon as the water values deviate from the settings, the pumps start dosing (after elapse of the switch-on delay).

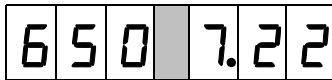

The  button is used to the control of chlorine/pH on or off.

Diode "Dosing on" lights	=	Control ON
Diode "Dosing on" off	=	Control OFF

### 10.3.1 Control limits

The dosing for Rx and pH is only released when the measured values are within specific limits. If this is not the case, a malfunction of the probe or measuring input is assumed and no dosing is carried out.

If one of the values is outside the limits, the display of the particular value starts flashing.

Limits:	Redox:	50 - 950mV
	pH:	3 – 12

**Note:** If the actual value is outside the limits during commissioning, this value must be adjusted first by a manual addition of chemicals until it is within the required range.

## 10.4 dinoAccess remote visualization / remote control (option)

Requirements:

- Apple iPhone from iOS9 or
- Android smartphone from Android 6.0 (Marshmallow)
- Internet-enabled 2.4Ghz WiFi access point 5Ghz is **not** supported
- Automatic IP address assignment (DHCP) must be enabled
- WiFi access data

Download the **dinoAccess** app from the Apple App Store or Google Playstore.

1. Open app
2. Create account
3. Add CF Control (yellow "+" symbol)
4. Enter individual device name and device location -> Next
5. Enter WiFi access data -> Next
6. Switch to the WiFi settings on the smartphone and select the new device (starts with CF100). Switch back to dinoAccess.
7. The device connects automatically. After a successful connection, the app switches to the overview page.

### 10.4.1 Reset of WiFi settings

Attention – all settings and all connections to the app are lost during this operation. The data cannot be restored. After resetting, the device must be configured as a new device in the dinoAccess app. This does not change the configuration of the CF Control 100.

Resetting the WiFi settings: Go to the menu item "Device settings" in the dinoAccess app, click on "Delete system". Or set the value for parameter 0 to 800 directly on the CF Control 100.

### 10.4.2. Remote control (adjustment of setpoints, calibration of pH probe) via in-app purchase

The CF Control can also be operated remotely to adjust the set points and calibrate the pH probe. This function is available for a fee and can be activated via an in-app purchase.

### 10.4.3 Troubleshooting

1. The CF 100 is displayed as offline. Solution: Check the WiFi signal strength. If necessary, use a repeater or place the the router closer to the device.
2. Registration of the system in the app failed. Solution: Check the WiFi connection. Check the access data. If necessary, the WiFi configuration must be reset as described in 10.4.1.

## 11 Maintenance and servicing

The CF Control 100 is easy to maintain, but should be checked and serviced at regular intervals by a trained technician.

Please observe the following information on maintenance and servicing of the CF Control 100 as well as the separate manuals, e.g. for dosing pumps and probes.

If you have any further questions regarding our measuring, control and dosing system, please contact your dinotec pool dealer or our service department.

### 11.1 Cleaning and calibrating the electrodes

Depending on the water quality, the electrodes (measuring probes) must be cleaned and re-calibrated at intervals of 4-5 weeks (or more frequently, if required, e.g. in the case of highly ferrous water or salt deposits caused by brine water). Check the electrodes for any mechanical damage (e.g. breakage of glass) and wipe them dry with a soft paper towel. If there is scaling on the probe surface, the probes are immersed in our special liquid probe cleaner (0181-184-01) for about 1 minute and then rinsed thoroughly with water.

- If the metal pin of the redox electrode shows a brown coating, the metal pin must be cleaned with cleaning paste (0181-184-00) and rinsed thoroughly with water. Afterwards, dry the pH electrode with a soft paper towel. A calibration is not required in this case.  
The redox electrode is wear-free, provided there is no mechanical damage.
- Re-calibrate the pH electrode with calibration solutions pH 7 and pH 4 and reinsert it into the measuring cell.  
The service life of pH electrodes depends to a high degree on operating conditions and maintenance. The normal service life is between 1 and 2 years. The pH electrode is a wearing part.

**ATTENTION:** Before removing the probes, switch off the dosing and close the sample water inlet and outlet at the sampling points.

**NOTE:** Deposits on the diaphragm of the pH probe can lead to malfunction (pH value jumps); in this case the probe is to be cleaned with a liquid probe cleaner.

**WARNING:** *Other acids or cleaning agents can destroy the probes.*

### 11.2 Cleaning the measuring cell

Normally the measuring cell requires no inside cleaning. If the red float for the monitoring of sample water should "get stuck", you can try to get it moving again. Turn the sample water off for this purpose and unscrew the grey, ribbed water inlet out of the measuring cell. Place a bucket below the cell before doing that. There are **two O-rings** in the inlet of this measuring cell that **must be inserted again when reinstalling the cell**. If you insert only one O-ring by accident, the pressure of the sample water cannot push the float upwards.

**WARNING:** Please take care of the two O-rings during installation!

### 11.3 Wintering

If the measuring and control system is installed outdoors (shaft etc.), the complete system is to be disassembled and stored according to section 2 - Technical Data (observe permissible room temperature and humidity!). Otherwise, errors can occur in the devices due to condensation.

## 12 Alarm messages

### 12.1 List of error messages:

The following error codes are displayed, depending on the type of error:

- *Er0* – when the chlorine dosing container is empty (contacts 17, 18 closed)<sup>14</sup>
- *Er1* – when the pH dosing container is empty (contacts 19, 20 closed)<sup>14</sup>
- *Er2* – when the sample water monitoring has responded (see chapter 11.2)
- *Er3* – when a leakage is detected
- *Er4* – when the max. dosing time for chlorine is exceeded
- *Er5* – when the max. dosing time for pH reduce is exceeded
- *Er7* – when the temperature measurement of the pool water is not working properly
- *Er8* – when the temperature measurement of the solar absorber is not working properly
- *Er9* – when the max. dosing quantity per day is exceeded

### 12.2 Resetting of alarms

Alarms that are not terminated automatically after the cause has been eliminated



must be acknowledged by you. The  button is pressed for this purpose. (Please press for more than 2 seconds.) Each time this button is pressed, all current alarms are reset, provided the particular error has been removed/corrected.

---

<sup>14</sup> With optional suction lance with container empty signal equipment (accessory)

### 13 Troubleshooting

pH display flashes	-Measuring input faulty - Measured value outside the control range of 3-12 pH -Measuring probe / cable defective	S C C/S
Redox display flashes	-Measuring input faulty -Measured value outside the control range of 50-950 V -Measuring probe / cable defective	S C C/S
LED "Dosing on" flashes	Switch-on delay still in progress Please wait	
pH value too low	- If dinoplus liquid is added, check whether the pump is working properly - Check the dosing agent supply - Check calibration - Check dosing valve	C C C/S C/
pH value is too high	- If dinoplus liquid is added, check whether the pump is working properly - Check the dosing agent supply - Check calibration - Check dosing valve	C C C/S C/S
pH display deviates greatly from manual measurement	- Re-calibrate device with buffer solution pH 7/4 - Renew the buffer solution, if required - If there is no improvement, clean the probe or replace it, if required	C C C/S
Dosing LED on, but pump is not running	- Check if pump is supplied with voltage - Check control type (pulse interval /pulse frequency) - Check pump, replace if required	S S C
Pump in operation, but does not deliver	- Defect in pump area (see water guard dosing pump manual)	S
Three-way motorised ball valve (heating) switches incorrectly	- Exchange cables of terminals 8 + 9	
See solenoid switch incorrectly	- Exchange cables of terminals 8 + 9	
<b>Err 4, Err 5,</b> (4= chlorine, 5= ph reduce)	The dosing time monitor has responded: Check dosing system: Dosing line, dosing valve or dosing pump clogged? Container empty? Dosing line defective?	S

DES= Disinfection pump (chlorine)

C = Works that the customer/user can possibly carry out himself-

S = Works to be carried out by service staff; if required the device must be returned to the works.

**Warning:** A broken cable to the redox electrode or plug corrosion on this electrode is not reliably detected by the CF Control. It is not mandatory that the displayed redox potential changes to 0 mV. Errors of this kind can only be determined with a pH-T tester.

## 14 Technical data<sup>15</sup>

### 14.1 General

#### 14.1.1 General settings

Power supply	230 V/AC $\pm$ 10 % (50/60 Hz) or 115 V/AC $\pm$ 10 % (50/60 Hz) switching is automatic
Power consumption	10 VA
Protection class:	IP 65
Fuse (device)	250 V / 80mA T
Contact load, relay	max. 500 W, max. 250 V
Working temperature	0 to + 50° C
Permissible storage temperature	-20 to +65-c
Permissible humidity	max. 90% at 40°C (non-condensing)
Length of power cord	1.6 meter
Dimensions device	215 x 185 x 100 mm (w x h x d)
Dimensions mounting plate	600 x 360 x 8 mm (w x h x d)
Tonnage	1.8 kg
Switch-on delay	0 - 30min
Alarm output (only when operated as measuring and control instrument)	Normally closed contact (NCC) or normally open contact (NOC) (switchable)

#### 14.1.2 Settings chlorine control

Control characteristics	pH controller
Control response	On-Off or pulse frequency or pulse interval (adjustable)
Pulse frequency, if adjusted	1 - 7200 pulses/min. (adjustable in pulses)
Pulse duration in case of pulse frequency	250 ms constant
Minimum pulse in case of pulse interval, if adjusted	0.5 – 10 sec. (adjustable in steps of 0.1 sec)
Period in case of pulse interval, if adjusted	10 – 60 sec. (adjustable in sec.)
Permanent dosing time monitoring	0 – 90 min. (adjustable in min.)
Permanent monitoring of dosing quantity	0 – 30 liters/day (adjustable in steps of 0.1 liter)
Dosing capacity	0.5 – 8 liters / hour (adjustable in steps of 0.1 liter)

<sup>15</sup> For information and data about dosing quantities, counter pressures etc., refer to the manual of the dosage pumps installed in your system please.

**14.1.3 Settings pH control**

Control characteristics	P controller (proportional controller)
Control direction	Raise and reduce (switchable)
Control response	On-Off or pulse frequency or pulse interval (adjustable)
Pulse frequency, if adjusted	1 - 7200 pulses/min. (adjustable in pulses)
Pulse duration in case of pulse frequency	250 ms constant
Minimum pulse in case of pulse interval, if adjusted	0.5 – 10 sec. (adjustable in steps of 0.1 sec)
Period in case of pulse interval, if adjusted	10 – 60 sec. (adjustable in sec.)
Permanent dosing time monitoring	0 – 90 min. (adjustable in min.)
Permanent monitoring of dosing quantity	0 – 30 liters / day (adjustable in steps of 0.1 sec.)
Measuring resolution pH	0.01 pH
Measuring range pH	0 – 14 pH
Control range pH	3 - 12 pH
Hysteresis pH	0.0 – 1.0 pH (adjustable in steps of 0.1 pH)
Dosing capacity	0.5 – 8 liters / hour (adjustable in steps of 0.1 liter)

## 14.2 Factory settings (default values)

### 14.2.1 Redox measuring and control part

Set point	600 mV
P-band	100 mV
Control response	Operating mode pulse interval
Minimum pulse in case of pulse interval, if adjusted	1 sec.
Period in case of pulse interval, if adjusted	30 sec.
Pulse frequency, if adjusted	7200 pulses/min
Pulse duration in case of pulse frequency	250 ms constant
Permanent dosing time monitoring	60 minutes
Switch-on delay	5 minutes
Permanent monitoring of dosing quantity	0 (deactivated)
Dosing capacity	3 litres

### 14.2.2 pH measuring and control part

Setpoint	7.2
P-band	0.5 pH
Slope of pH probe	58 mV/pH
Zero point of pH probe	7.0 pH
Temperature compensation	28 °C
Switching point hysteresis	0.1 pH
Control response	Operating mode pulse interval
Minimum pulse in case of pulse interval, if adjusted	1 sec.
Period in case of pulse interval, if adjusted	30 sec.
Pulse frequency, if adjusted	7200 pulses/min
Pulse duration in case of pulse frequency	250 ms constant
Permanent dosing time monitoring	60 minutes
Switch-on delay	5 minutes
Permanent monitoring of dosing quantity	0 (deactivated)
Dosing capacity	3 litres

## 15 Service / Basic settings

This chapter refers to settings which may only be carried out by qualified personnel for initial commissioning and after fundamental changes to the system.

### 15.1 Function: Delete data memory (reset factory settings)

This function should only be used by trained service staff. This is why this function cannot be easily selected and triggered. All settings are reset to the original factory default parameters. The menu navigation and the following parameters are used for a reset:

Parameters	Function
00	<p>CODE</p> <p>00 = End user code                      NN = Code for pool dealers / service staff                      NN: Code for dinotec factory service.</p> <p>997: Load factory settings (excluding calibration values)                      999: = Set calibration values (0mV, 58mV/pH)</p>

Note: A re-calibration of the pH electrode is not required after having entered the function value 997 (factory settings).

### 15.2 Parameter table for service staff

Entry of service code C is required for access to the following parameters:

Parameters	Function	Factory settings
8	Minimum flow in l/h (10 – 50)	15 l/h
19	Flow in pulse/l (0 - 1000)	0
51	Max. pulse frequency relay 1 in (pulse/h * 100)	72 (= 7200 pulse/h)
52	Period relay 1 in sec.	30 sec.
53	Minimum pulse duration relay 1 in 0.1 sec.	10 (=1 sec.)
56	Max. pulse frequency relay 2 in (pulse/h * 100)	
57	Period relay 2 in sec.	30 sec.
58	Minimum pulse duration relay 2 in 0.1 sec.	10 (= 1 sec.)

---

Parameters	Function	Factory settings
61	Max. pulse frequency relay 3 in (pulse/h * 100)	72 (= 7200 pulse/h)
62	Period relay 3 in sec.	30 sec.
63	Minimum pulse duration relay 3 in 0.1 sec.	10 (= 1 sec.)

## 16 Maintenance and servicing - Summary

Time intervals	To be checked	How?
Weekly	Check water - pH value - chlorine level  Fiber filter - visual check  Flow valve - visual check  Flow control monitor - visual check	With tester Ideal value: 7.0 - 7.4 pH Ideal value: approx. 0.3 - 0.8mg/l  Free flow  Free flow  Free flow
Monthly	pH electrode  Redox electrode, if existing	Check and clean according to manual. Re-calibrate, if required  Check and clean according to manual. Calibrate after manual measurement.  Reduce intervals in case of higher loads
Indoor pools after 6 months	Buffer solution pH 7, pH 4	Replace with fresh calibration solution
Annually	pH electrode Redox electrode, if existing	Check operability, see manual. Clean or replace if required

Outdoor pools at the end of the season	Buffer solution pH 7 / 4	Cannot be used, order in due time before the start of the season
	<u>Wintering in non-frost-proof room</u>	
	- Measuring amplifier	OFF
	- pH electrode - Redox electrode, if existing	Take out of the flow valve, close contacts with protective cap, put into a small bottle containing potassium chloride solution or water to prevent drying
	Flow valve/pipe	Empty and bring into frost-proof room
	Dosing liquids:	Close properly and keep in a cool and dry place.
	- pH correction chemicals	Should be used up, if possible
	- dinochlorine	Pump with clean water, switch to OFF
	Dosing pumps	
	<u>Wintering in frost-proof room</u>	OFF
- Measuring amplifier	Remain in the flow valve together with water	
- pH electrode - Redox electrode, if existing	Close	
- Sample water extraction and return	See above	
- Dosing liquids	see above	
- Dosing pumps		

## 17 APPENDIX

### 17.1 Liquid dosing agents for your CF Control 100 system

You desire hygienically clean and crystal-clear water in order to feel good and relax in your pool?

The Chemoform system provides everything required for this purpose. To ensure a trouble-free operation of the system, it is also important that you use only treatment agents that are compatible with our devices, and where quality and effectiveness have been tested by dinotec.

<b>NOTE:</b>	Use only accessories and water care agents which have been tested and recommended, and which are specially developed for this area of application and are subject to continuous quality controls.
--------------	---

The following treatment agents are available from your pool dealer.

Please use the following products:

- dinochlorine liquid for disinfection
- dinominus liquid for lowering the pH level
- dinoplus liquid for raising the pH level
- dinofloc Ultra liquid removal of turbidity in the water

For article numbers, supply sizes and prices, refer to our current price list at <https://gb.dinotec.de/downloads/preislisten-kataloge>

**Do not use any organic chlorine compounds!**

<b>CAUTION:</b>	Keep the dinochlorine dosing agent in a cool and dry place. Keep out of direct sunlight.
<b>Do not mix different dosing agents. Please observe the relevant information and safety instructions on the product labels.</b>	

<b>WARNING:</b>	The use of concentrated hydrochloric acid in the immediate vicinity of our equipment invalidates the guarantee!
-----------------	---

**18 Accessories and Spare Parts**

0161-101-01 pH combination electrode  
0111-103-00 Redox electrode without reference system  
0101-140-00 Calibration solution pH 7  
0101-139-00 Calibration solution pH 4  
0991-354-00 Temperature sensor Water PT 1000  
0991-356-00 Temperature sensor Solar PT 1000  
0986-151-00 Submerged tube for temperature sensor water

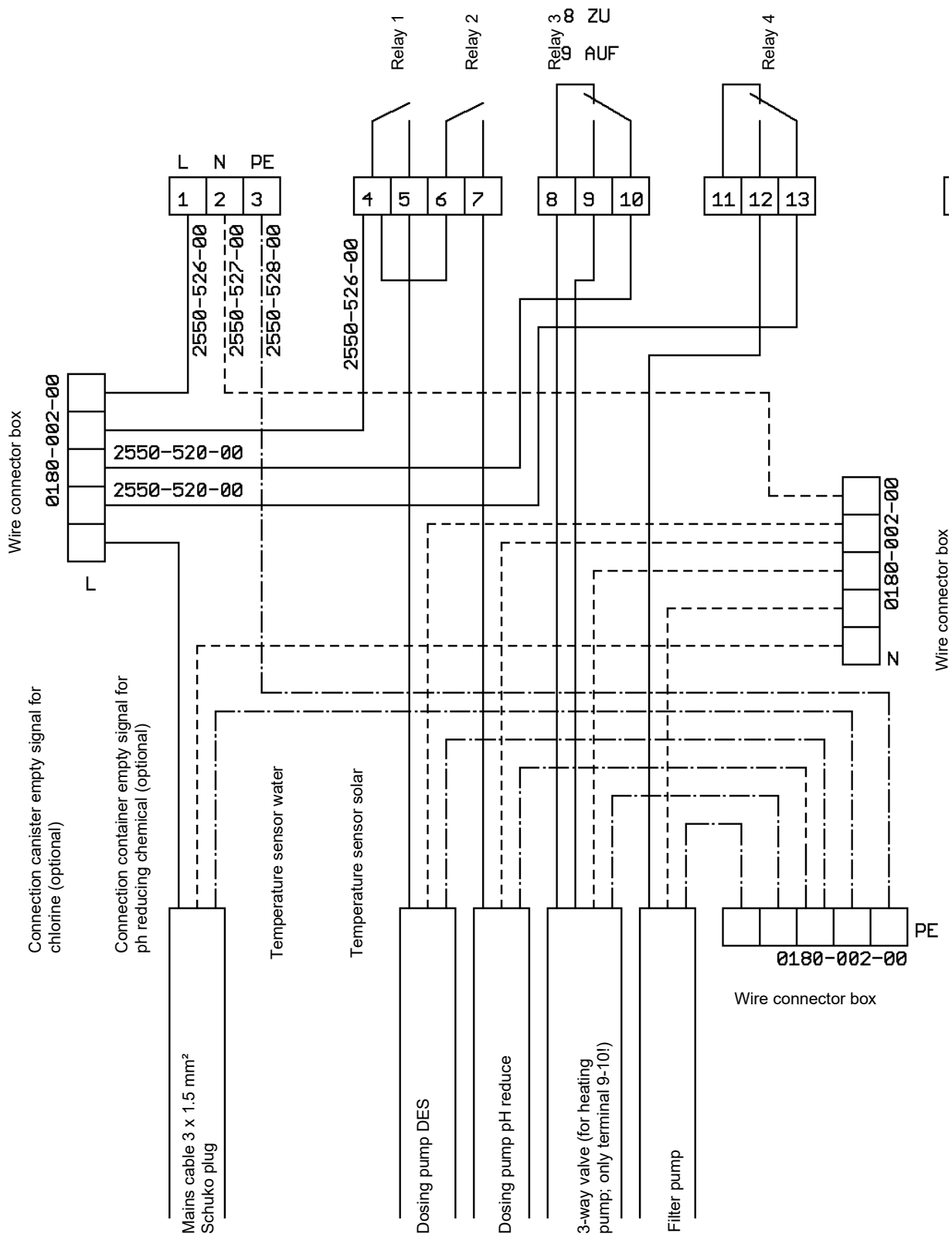

## 19 Electrical connection diagram

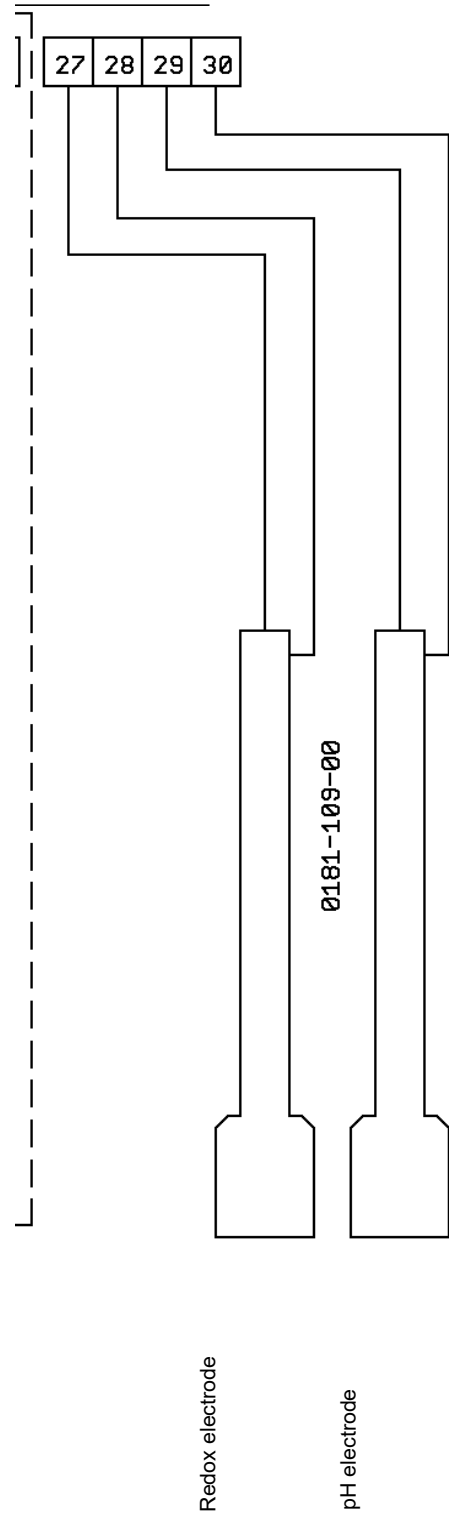
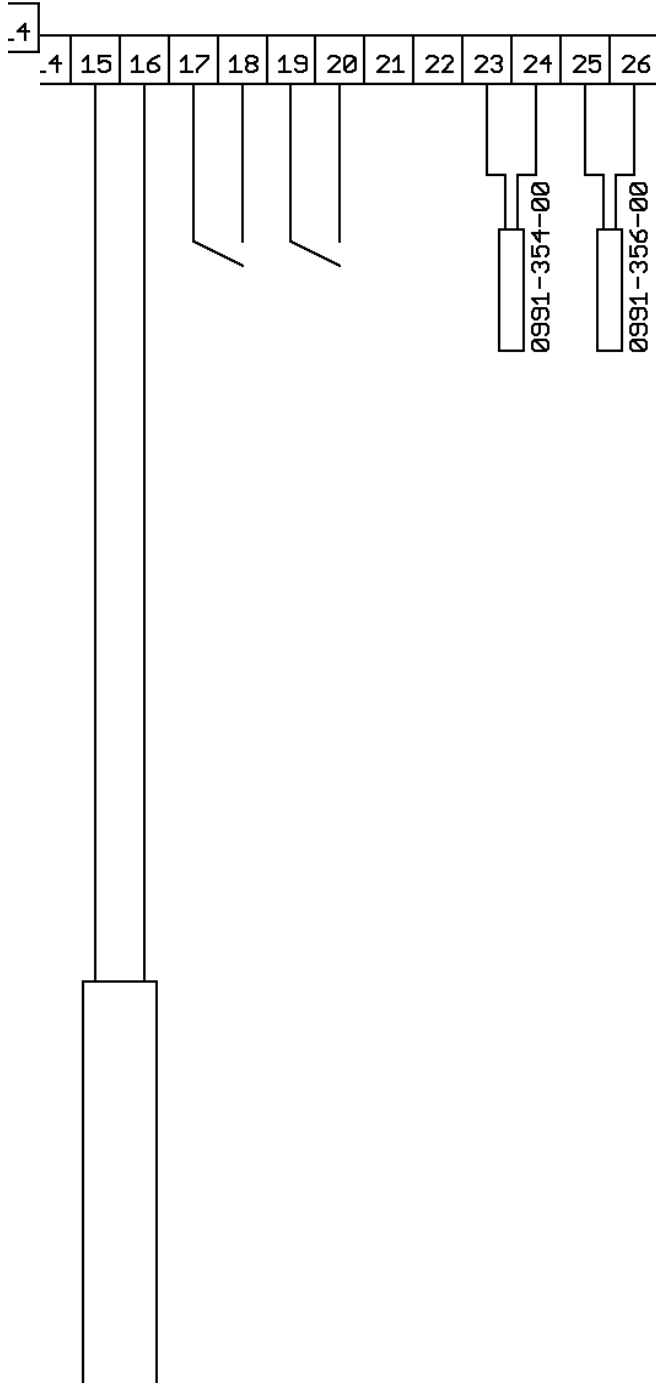

**Chemoform AG** – Bahnhofstr. 68 - D-73240 Wendlingen  
Telephone: +49 (7024) 4048-0 – Fax: +49 (7024) 4048-2800  
[info@chemoform.com](mailto:info@chemoform.com)  
[www.chemoform.com](http://www.chemoform.com)  
[www.dinotec.de](http://www.dinotec.de)